

PROTEAM™ by HAUSMANN

ATHLETIC TRAINING EQUIPMENT CATALOG



PROTEAM STRONG - Over 5,000 installations and building...

LAMINATE AND TABLE VINYL SELECTOR

Laminate Color Selection



346 Natural Oak



5904 Wild Cherry

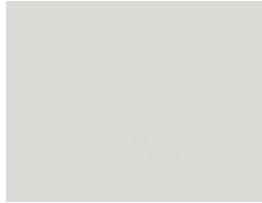

927 Folkstone Gray

THE LAMINATE ADVANTAGE

- Durability
- Scratch & Dent Resistance
- Easy to Disinfect



Pro-FORM™ Vinyl Colors *(CAL133 - Boston Fire Rated tops are available at an up charge. Specify "BF" when ordering)*



718 Navy Blue



722 Dove Gray



723 Forest Green



724 Deep Wine



725 Black



731 Regimental Blue



729 Royal Blue



730 Purple



728 Claret



726 American Beauty

ABOVE PRINTED COLORS MAY VARY FROM ACTUAL MATERIAL

Hausmann Industries is pleased to present the latest edition of the PROTEAM™ catalog, representing the full line of athletic training room furnishings and products focused on the medical and rehabilitation markets. This catalog features innovative designs and product enhancements that meet the evolving roles and changing settings of today's athletic trainer – such as Hausmann's tablet-based facility design program using the MagicPlan™ app (see page 7).

For over 15 years, PROTEAM has been the choice of athletic trainers for their training room furnishings. PROTEAM products feature durable, maintenance-free laminate surfaces for years of worry-free use. Our rugged Pro-Form vinyl with two-inch thick high-density foam tops ensures the extra durability needed in high-volume settings. Standard 3mm edging on all taping stations, treatment tables, carts, and cabinetry provides unparalleled durability.

Our modular taping stations fit any space and need. With exceptional versatility, modules can be added, changed, or relocated as necessary. PROTEAM offers a wide range of treatment tables, from traditional open storage tables to cabinet-style tables featuring optional backrests and elevating split legs. Add embossed or debossed logos to any taping station, treatment table or stool to personalize athletic training rooms. Logos are now available on mat platforms, featuring our new PROPRINT™ technology.

PROTEAM is the market leader - from taping stations and treatment tables to stools, carts, and cabinets - backed by over 60 years of manufacturing expertise.

PROTEAM STRONG - Over 5,000 installations and building...

David Hausmann

Chief Executive Officer
Hausmann Industries, Inc.

George Batchelor

Dir. of Sales & Marketing
Hausmann Industries, Inc.

Joe Patten





National Sales Manager
PROTEAM





We are proud to manufacture all of our wood products in the U.S.A. since 1955.

<p>2</p>  <p>New Product Showcase</p>	<p>3-6</p>  <p>Modular Taping Stations</p>	<p>7</p>   <p>MagicPlan</p> <p>Planning and Design</p>
<p>8-9</p>  <p>Logos</p>	<p>10</p>  <p>Treatment and Taping Tables</p>	<p>11-12</p>  <p>Cabinet Tables</p>
<p>13-15</p>  <p>Split Leg Tables</p>	<p>17-19</p>  <p>Specialty Treatment Tables</p>	<p>20-21</p>  <p>S&W by Hausmann</p>
<p>22-25</p>  <p>Power Treatment and Exam Tables</p>	<p>26-29</p>  <p>Mat Platforms</p>	<p>30-37</p>  <p>Weights, Racks, and Storage</p>
<p>39-40</p>  <p>Stools</p>	<p>41-43</p>  <p>Carts</p>	<p>45-48</p>  <p>Cabinets, Lockers, and Wardrobes</p>

These colorful icons will appear throughout our catalog as a quick, easy-to-recognize reference to product features:

-  **Industry Leading Quick Ship Program**
The program continues to improve: more products, shorter lead times, addition of our new 1 Day QS and On-Time Performance of over 98%. Products are guaranteed to ship from factory in 1, 3, 5, or 10 business days after receipt of approved order or we pay the freight. Additional transit time varies by destination and carrier. Quick Ship guarantee is for a maximum of 3 items.
-  **3 Days**
-  **5 Days**
-  **10 Days**

 **"Peace of Mind" 3-Year Limited Warranty**
Covers defects on ALL Hausmann products under normal use.

 **Weight Capacity**
The maximum weight this product can accommodate. Weight capacity is shown next to each product.

 **Bariatric Equipment**
This product is designed to accommodate obese individuals. Product weight capacity is 500 lbs. or greater.

 **Wheelchair Accessible**
This product is designed for wheelchair access.

 **UL Listed**
This product is listed by Underwriters Laboratory and meets UL 60601 Medical Standards for Safety. All UL Listed products meet Canadian UL (CUL).

 **Hi-Impact 3mm Edging**
Rounded edges on door and drawer fronts will not dent or peel for enhanced safety and durability.

 **Green-Line Product**
Eco-friendly construction for safer indoor environment.

Single Seat Taping Station
Model A9400
page 3



Hip and Knee Flexion
Split Leg Table
Model A9069
page 15



Recovery Table
Model A9021
page 17



PRO-Options Table
Model A9075
page 17



Convertible
Taping Bench/
Treatment Table
Model 4062
page 19



Whirlpool Table featuring
Starboard® ST Tops with Cabinet
Model AT825
page 21



2-Section Hi-Lo Treatment
Table with Armrests
and Glides
Model 6071
page 24



3-Section Mobile Hi-Lo
Treatment Table with
Locking Casters
Model 6074
page 24



PROPRINT™ Graphic on Mat Platforms
Option A931
page 29



Combination Rack with Whiteboard
Model 5558
page 33



Round Bolsters in Pro-Form™ Vinyl
Models 30-99 and 31-99
page 38



Pro-Line Cabinets available in
24" depth cabinets
page 46



COMMON FEATURES

PROTEAM MODULAR TAPING STATIONS:

- Upholstered Taping Modules are 36"H or 42"H. Storage Modules with laminate tops are 4" lower.
- You can order individual taping or storage modules. See page 6 or go to www.proteamtapes.com.
- Durable dowel and glue laminated wood construction for long term structural integrity.
- Self-closing laminate drawer with nylon rollers.
- Doors have concealed, adjustable, self-closing 110° Euro-hinges.
- All doors and drawer fronts have 3mm high impact edging.
- Cabinet backs are finished.
- Taping station end units have side open storage with (1) adjustable shelf.
- Comfortable 2" thick high-density foam upholstered tops are removable without tools.

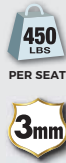

COLORS: (SEE INSIDE FRONT COVER)

Laminate* - Natural Oak, Wild Cherry, or Folkstone Gray

Upholstery* - 10 Pro-Form™ vinyl colors

*Custom laminate and upholstery available

A. MODEL A9521

with options



A. MODEL A9521

2-SEAT TAPING STATION WITH OPTIONS

SHOWN L TO R:

- A918 Full Extension Pullout
- A926 Fixed 75° Upholstered Back
- A923 Set of (3) Drawers
- A924 Waste Hamper
- A945 Top Drawer Lock
- A944 Full Height Doors
- A946 Lock/Bolt
- A929 Side Pull-Out Stand

MODEL	LENGTH	DEPTH	HEIGHT
A9521	6'	42"	36"

B. MODEL A9400

SINGLE SEAT TAPING STATION

- Full extension pullout for tape storage opens to the side.
- Two 8" self-closing laminate drawers with nylon rollers for extra deep storage to the side for easy access to supplies.
- Large side storage compartment with shelf includes door with concealed, adjustable, self-closing 110° Euro-hinges.
- Left hand configuration is standard.
- Taping station can be configured left or right. Please specify for right hand configuration

MODEL	WIDTH	DEPTH	HEIGHT
A9400	28"	42"	36"
A9401	28"	42"	42"



Reverse side has solid back

B. MODEL A9400

Shown as left hand unit (standard configuration)

Option A926 Fixed 75° Upholstered Back



OPTIONS

MODELS A9400, A9401

- *A926 - Fixed 75° Upholstered Back
- *A945 - Door/Drawer Lock
- *99-R - Pullout, drawers, and door are on left when facing taping station

*FACTORY INSTALLED

MODULAR TAPING STATIONS

A. MODEL A952X 2 SEAT MODULAR TAPING STATION — 6 FT. LONG

MODEL	HEIGHT	DEPTH
A9520 *	36"	36"
A9521	36"	42"
A9522	36"	48"
A9523*	42"	36"
A9524	42"	42"
A9525	42"	48"

*A926 not available on 36" depth.

B. MODEL A953X 3 SEAT MODULAR TAPING STATION — 10 FT. LONG

MODEL	HEIGHT	DEPTH
A9530*	36"	36"
A9531	36"	42"
A9532	36"	48"
A9533*	42"	36"
A9534	42"	42"
A9535	42"	48"

*A926 not available on 36" depth.

C. MODEL A954X 4 SEAT MODULAR TAPING STATION — 14 FT. LONG

MODEL	HEIGHT	DEPTH
A9540*	36"	36"
A9541	36"	42"
A9542	36"	48"
A9543*	42"	36"
A9544	42"	42"
A9545	42"	48"

*A926 not available on 36" depth.



A. MODEL A9520



B. MODEL A9534
Shown with
multiple options



C. MODEL A9540

Visit www.proteamtables.com/literature.html
for Taping Station Design Templates



D. MODEL A9520-346-24
includes A924 Waste Hamper

D. MODEL A9520-346-24 QUICK-SHIP 2-SEAT TAPING STATION WITH HAMPER



SPECIAL FEATURES:

- Same as A9520 but includes A924 Hamper. No other options available.
- This Quick-Ship item is Oak laminate in size shown with choice of 10 Pro-Form™ vinyl colors.

MODEL	LENGTH	DEPTH	HEIGHT
A9520-346-24	6'	36"	36"

See Common Features on page 3.



A914
EXTRA (1) DRAWER



A918
FULL EXTENSION PULL-OUT



A943
HINGED SIDE ACCESS DOOR



A944*
FULL HEIGHT DOORS



A9250
VELCRO WALL PAD, 24"W x 24"H
Shown mounted to wall



A927*
FRONT PULL-OUT STAND AND DRAWER
Shown with Option A918



A923*
(3) DRAWERS (in lieu of doors)



A924*
WASTE HAMPER AND CUTOUT



A926*
FIXED 75° UPHOLSTERED BACK, 26"H x 10"D
Only available on 42"D or 48"D units



A941*
LAMINATE TOP WITH 3MM EDGING



A945* LOCK
A946* LOCK-BOLT
A947 4" SATIN FINISH WIRE PULL



A929*
SIDE PULL-OUT STAND

*FACTORY INSTALLED

NOTE: All dimensions shown are nominal. Please define exact length if wall to wall.

TAPING MODULES – FRONT AND DUAL SIDE ACCESS – 2" UPHOLSTERED TOP

36" HIGH - FINISHED BACKS

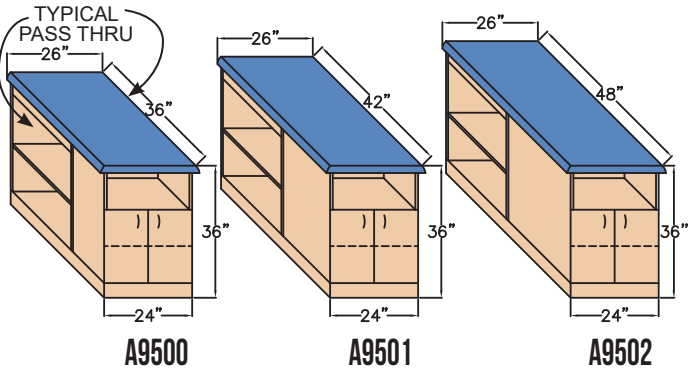

42" HIGH - FINISHED BACKS

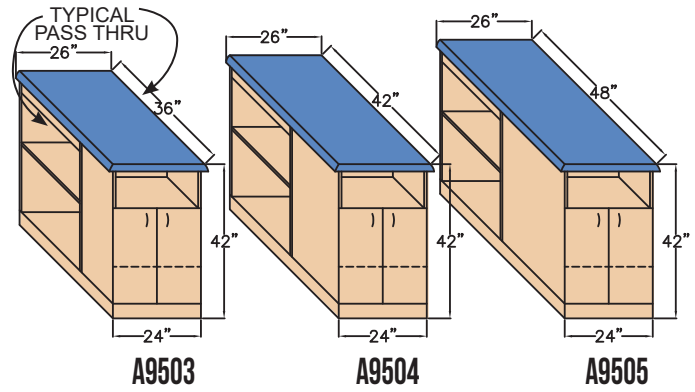

TAPING MODULES – FRONT ACCESS FULL DEPTH STORAGE – 2" UPHOLSTERED TOP

36" HIGH - FINISHED BACKS

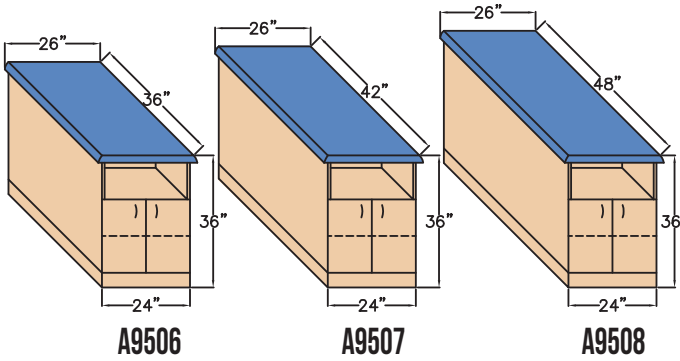

42" HIGH - FINISHED BACKS

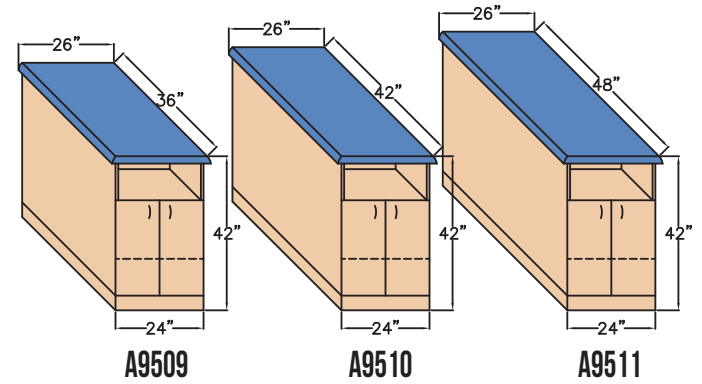

NOTE: You can "Mix & Match" any module on this page to achieve different overall height levels. For example, you can have a 36" high taping module and a 42" high taping module in the same taping station. Please specify on P.O.

STORAGE MODULES – FRONT ACCESS FULL DEPTH STORAGE – 1" LAMINATED TOP

NOTE: Width can be reduced to 18" if needed - Specify 18" W on P.O.

**32" HIGH - FINISHED BACKS
(FOR USE WITH 36"H TAPING STATION)**

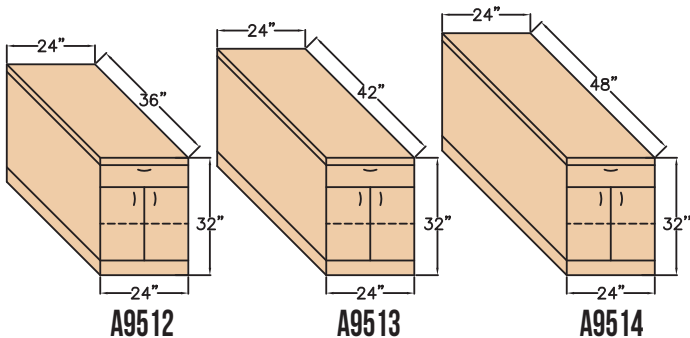

**38" HIGH - FINISHED BACKS
(FOR USE WITH 42"H TAPING STATION)**

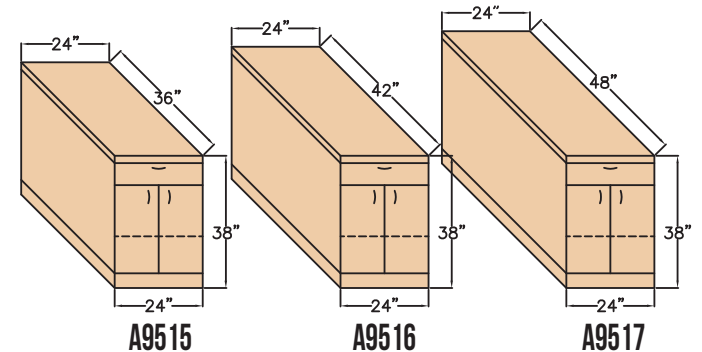

NOTE: All dimensions shown are nominal. Please define exact length if wall to wall.

Designing an Athletic Training Room



IS AS EASY AS 1-2-3
 using the PROTEAM™ MagicPlan™ Design App



Capture room corners with camera or draw room dimensions

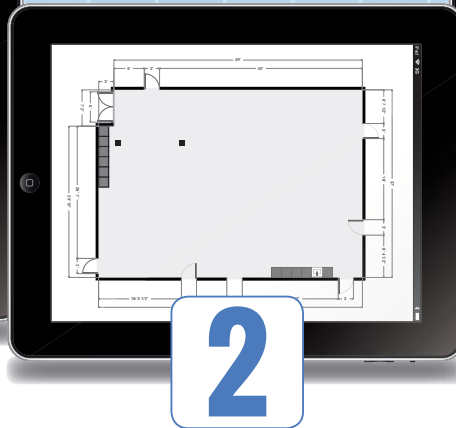

Refine room dimensions and add structural attributes

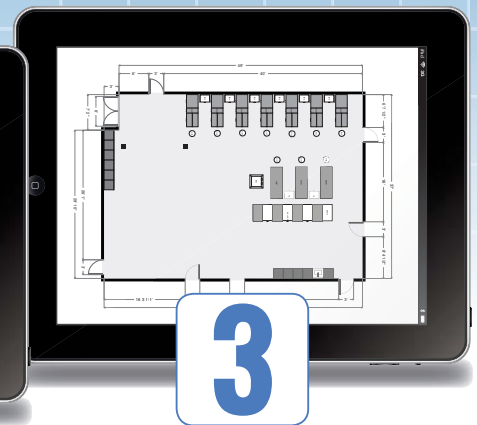

Click and Drag PROTEAM™ equipment into your room plan

- Add laminate & vinyl options and accessories to your PROTEAM™ products
- Create your own objects to customize your plan
- Add rooms to your plan
- Update and modify your plan as often as needed
- Export your plan in PDF, JPEG, DXF & HTML formats

For more information visit:
www.proteamtables.com/roomdesign

or email us:
design@proteamtables.com

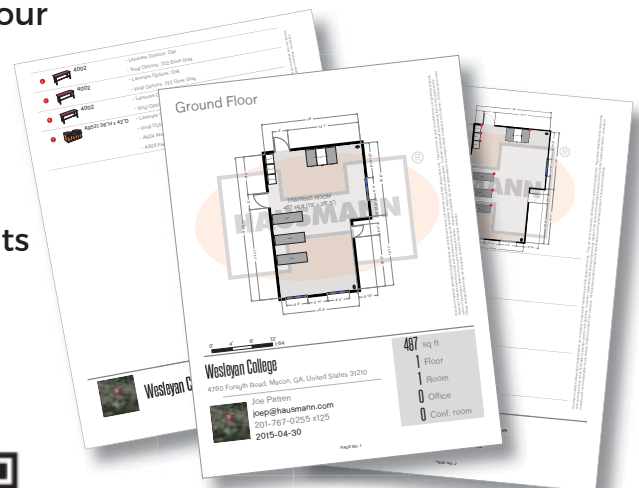

Athletic Training Room layouts created using the MagicPlan™ App featuring PROTEAM™ products

INSTALLATIONS



SHOW YOUR TEAM PRIDE... MAKE YOUR TRAINING ROOM POP!

Brand your equipment with your team logo embossed or debossed onto our heavy duty vinyl upholstery.

It's PROTEAM Tough & Cleanable - unlike silk screening, decals or embroidery.

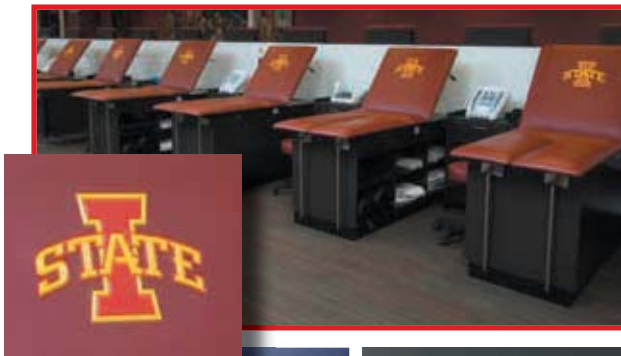

Debossed logo ▲

OPTION	DESCRIPTION
A900*	6" Deboss Plate (Stool Tops only)
A901*	12" Deboss Plate
A902	Deboss Logo
A903*	12" Emboss Plate
A904	Emboss Logo ONE Color
A905	Emboss Logo TWO Color
A906	Emboss Logo THREE Color
A907	Emboss Logo FOUR Color
A908	Emboss Logo FIVE Color
-L	Debossed Stool Logo (Stool Tops only)

* Vector art is preferred for proper logo processing.

Contact your PROTEAM dealer for custom logo ordering information.

Scan QR code for artwork specifications.



Embossed logo ▼



Your team logo graphics are permanently embedded into the high pressure laminate surface... so logo will never peel or fade away. Washable, wear resistant and carefree.

Logo can be printed on vertical 24"W x 30"H back panel and/or on 24"W storage cabinet horizontal work surface.

Standard laminate background color is Black HPL, however other background color choices can be used & will match the (10) Pro-Form™ upholstery colors shown on inside front cover.

Contact your dealer for laminate logo ordering information at time of order. Scan the QR code above for artwork specifications.

OPTION	DESCRIPTION
A910*	Laminate Logo Setup Fee
A911	Laminate Logo Wall Plate
A912	Laminate Logo Storage Top

* Vector art is preferred for proper logo processing.

Your team logo graphics can be embedded on sides, door and drawer fronts (See page 16).

TREATMENT TABLES/TAPING TABLES



A. MODEL A9087



B. MODEL A9024



Model A9041 Open storage cabinet

COMMON FEATURES

TREATMENT TABLES –
MODELS A9002, A9024, A9041, A9087:

- 30" x 78" upholstered top with comfortable 2" thick high-density foam.
- High-pressure laminate legs, apron and H-Brace.
- Enhanced leg hardware system.
- Legs have protective black vinyl scuff caps.

COLORS: (SEE INSIDE FRONT COVER)

Laminate – Natural Oak or Wild Cherry
Upholstery – 10 Pro-Form™ vinyl colors

A. MODEL A9087 600 LB. TRAINERS TABLE

SPECIAL FEATURES:

- (6) Legs and plywood top for added strength.
- Laminate shelf with (2) long stretchers.

MODEL	LENGTH	WIDTH	HEIGHT
A9087	78"	30"	31"

OPTIONS

MODELS A9002, A9024, A9041, A9087

*69 – Gas Spring Backrest 0° to 75°

*FACTORY INSTALLED



B. MODELS A9002, A9024, A9041 TREATMENT TABLE

SPECIAL FEATURES:

- A9024 has full width laminate shelf.
- A9041 has laminate shelf and open storage cabinet.
- Additional sizes available.

MODEL	LENGTH	WIDTH	HEIGHT
A9024	78"	30"	31"

A9002 (not shown) same as A9024 w/o shelf

A9041 (inset) same as A9024 w/open storage



C. MODEL A9093 H-BRACE TAPING TABLE

SPECIAL FEATURE:

- 36" is convenient height for taping.

MODEL	LENGTH	WIDTH	HEIGHT
A9093	48"	27"	36"

D. MODEL A9097 H-BRACE TAPING TABLE WITH END CABINET

SPECIAL FEATURE:

- End facing open storage cabinet.

MODEL	LENGTH	WIDTH	HEIGHT
A9097	48"	27"	36"

ENHANCED LEG HARDWARE SYSTEM

Attach or detach legs quickly and easily with heavy-duty 5/16" bolts into embedded



metal threaded inserts for durable connection. Easily tighten and re-tighten as needed.



C. MODEL A9093

NEW 27" WIDTH

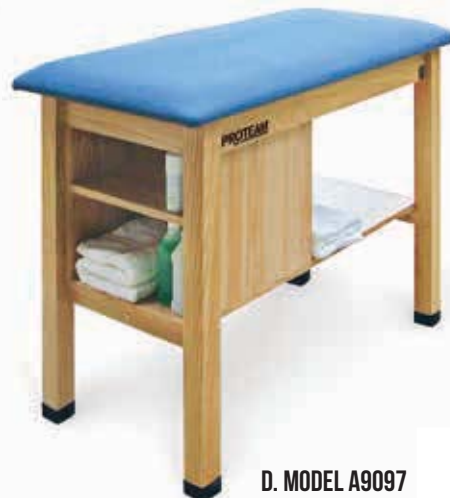

D. MODEL A9097

COMMON FEATURES

TAPING TABLES –
MODELS A9093, A9097:



- H-Brace is recessed into table leg with unique 4-sided "Lock-Tite" joint.
- High pressure laminate legs, apron and stretchers.
- Legs have protective black vinyl scuff caps.
- Comfortable 2" thick high-density foam upholstered top.

COLORS: (SEE INSIDE FRONT COVER)

Laminate – Natural Oak

Upholstery – 10 Pro-Form™ vinyl colors

A. MODEL A9066
TREATMENT TABLE WITH OPEN SHELF STORAGE



- Open shelf storage, accessible from both sides of the table.
- Center section has fixed shelves. Left and right sections have (1) adjustable shelf.
- Comfortable 2" thick high-density foam upholstered tops.
- Natural Oak, Wild Cherry, or Folkstone Gray laminate.
- 10 Pro-Form™ vinyl colors (specify).

MODEL	LENGTH	WIDTH	HEIGHT
A9066	78"	30"	31"



A. MODEL A9066

B. MODEL A9067
CABINET TREATMENT TABLE



- (6) Hinged doors on both sides of table.
- Storage accessible from both sides of table.
- Center section has fixed shelves. Left and right sections have (1) adjustable shelf.
- Comfortable 2" thick high-density foam upholstered tops.
- Natural Oak, Wild Cherry, or Folkstone Gray laminate.
- 10 Pro-Form™ vinyl colors (specify).

MODEL	LENGTH	WIDTH	HEIGHT
A9067	78"	30"	31"



B. MODEL A9067



Model A9067 shown with doors open

OPTIONS

MODELS A9066, A9067, A9073

*69 - Gas Spring Backrest 0° to 75° (A9066, A9067 center fixed shelves move to head section.)

*A946 - (1) Lock/Bolt for Double Doors

*FACTORY INSTALLED

C. MODEL A9073
CABINET TABLE



- (3) Two-door cabinets with laminate interiors and adjustable shelf.
- Solid finished back.
- Comfortable 2" thick high-density foam upholstered tops.
- Natural Oak, Wild Cherry, or Folkstone Gray laminate.
- 10 Pro-Form™ vinyl colors (specify).

MODEL	LENGTH	WIDTH	HEIGHT
A9073	78"	30"	31"



C. MODEL A9073



A. MODEL 4839

A. MODEL 4839
ORTHOPEDIC/HAND SURGERY TABLE



- New Lockable slide-out shelf.
- Shelf is 24"W x 13"D and fully adjustable in depth with locking knob.
- Two fully enclosed door cabinets.
- Each door cabinet is equipped with (1) adjustable laminate shelf.
- Concealed, self-closing Euro-hinges.
- Two all laminate drawers on nylon rollers.
- 2" High-density urethane foam top.
- Natural Oak, Wild Cherry, or Folkstone Gray laminate.
- Choice of (10) Pro-Form™ vinyl colors.

MODEL	LENGTH	WIDTH	HEIGHT
4839	78"	30"	31"



B. MODEL 4143



C. MODEL 4079

OPTIONS

MODEL 4079, 4143, 4839

- *07 - Nose Cutout
- 23 - Paper Dispenser
- 25 - Paper Cutter
- 27 - Paper Dispenser & Cutter Combo
- 32 - Pillow, full size
- 35 - Pillow, small
- *69 - Gas Spring Backrest 0° to 75°  (4079 only)
- *99L - Left Hand Table Model
- *A946 - (1) Lock/Bolt for Double Doors

*FACTORY INSTALLED

B. MODEL 4143
SPACE-SAVER CABINET TREATMENT TABLE



- Space-Saver Tables meet your needs for a full size table in a compact space.
- Full width 20" long foot end folds down to reduce table length to 52".
- Positive action locking device allows the foot end to be easily elevated into three positions: 55°, 75°, and 90°.
- Fully enclosed all laminate cabinet.
- Two hinged doors with 3mm edging.
- Concealed, self-closing Euro-hinges.
- Laminate interiors with (1) adjustable shelf.
- Black laminated plywood base.
- Natural Oak, Wild Cherry, or Folkstone Gray laminate.
- Choice of (10) Pro-Form™ vinyl colors.

MODEL	LENGTH	WIDTH	HEIGHT
4143	52" - 72**	24"	31"

* Fully extended

C. MODEL 4079
MODALITY TREATMENT TABLE



- Designed to save time and effort with modality equipment at your fingertips.
- Spacious upholstered top with 2" high-density urethane foam.
- Two fully enclosed door cabinets with adjustable shelf.
- Mid-section of table has full extension 10"H x 23 3/4"W equipment compartment.
- Black laminate base has access holes on both ends and back for cord and plug.
- Natural Oak laminate only.
- Choice of (10) Pro-Form™ vinyl colors.

MODEL	LENGTH	DEPTH	HEIGHT
4079	78"	30"	31"



A. MODEL A9068

Shown with options:
 69 - Gas Spring Backrest
 (3) A946 Lock/Bolts
 (1) A905 Embossed Logo



COMMON FEATURES

SPLIT LEG TABLES - MODELS A9064, A9065, A9068:

- Extremely versatile and functional split leg design.   
- Each padded leg rest can be adjusted and locked into desired angle up to 45° with spring-loaded lock-in lever.
- Comfortable 2" thick high-density foam upholstered tops.

COLORS: (SEE INSIDE FRONT COVER)

Laminate - Natural Oak, Wild Cherry or Folkstone Gray

Upholstery - 10 Pro-Form™ vinyl colors

OPTIONS

MODELS A9064, A9065, A9068

*69 - Gas Spring Backrest 0° to 75° 

*99-L - Left hand table (A9068 only)

*A946 - (1) Lock/Bolt for Double Doors

*FACTORY INSTALLED

B. MODEL A9064



A. MODEL A9068 SPLIT LEG TABLE

SPECIAL FEATURES:

- Six hinged doors with interior shelf offer concealed supply storage.
- Solid finished back.

MODEL	LENGTH	WIDTH	HEIGHT
A9068	78"	30"	31"

B. MODEL A9064 SPLIT LEG TABLE

SPECIAL FEATURES:

- Six hinged doors with interior shelf on both sides of table.

MODEL	LENGTH	WIDTH	HEIGHT
A9064	78"	30"	31"

C. MODEL A9065



C. MODEL A9065 SPLIT LEG TABLE

SPECIAL FEATURES:

- Open shelf storage, accessible from both sides of the table.

MODEL	LENGTH	WIDTH	HEIGHT
A9065	78"	30"	31"

COMMON FEATURES

SPLIT LEG TABLES – MODELS A9063, A9088, A9718:

- Extremely versatile and functional split leg design.
- Each padded leg rest can be adjusted and locked into desired angle up to 45° with spring-loaded lock-in lever.
- Comfortable 2" thick high-density foam upholstered tops.

COLORS: (SEE INSIDE FRONT COVER)

Upholstery – 10 Pro-Form™ vinyl colors



A. MODEL A9063

Shown with option:
69 – Gas Spring Backrest

**A. MODEL A9063
SPLIT LEG TABLE**



- Sliding doors on one side. Solid finished back.
- Natural Oak, Wild Cherry or Folkstone Gray laminate.

MODEL	LENGTH	WIDTH	HEIGHT
A9063	78"	30"	31"

**B. MODEL A9088
6-LEG SPLIT LEG TABLE**



- Six legs and full plywood subtop for added strength.
- Laminate shelf with (2) long stretchers.
- High-pressure laminate legs, apron and H-Brace.
- New enhanced leg hardware system.
- Legs have protective black vinyl scuff caps.
- Natural Oak or Wild Cherry laminate.

MODEL	LENGTH	WIDTH	HEIGHT
A9088	78"	30"	32"



B. MODEL A9088

C. MODEL A9718



**C. MODEL A9718
ELECTRIC SPLIT LEG TREATMENT TABLE**



- Durable motorized operation with "hands-free" foot control.
- Electro-hydraulic cylinders are built into (4) black powder coated steel legs with levelers.
- Fully enclosed oak laminate cabinet with sliding laminate doors.

MODEL	LENGTH	WIDTH	HEIGHT
A9718	78"	30"	27" - 37"

OPTIONS

MODELS A9063, A9088, A9718

*69 – Gas Spring Backrest 0° to 75° 

*99-L – Left hand table (A9063 and A9718.)

*FACTORY INSTALLED

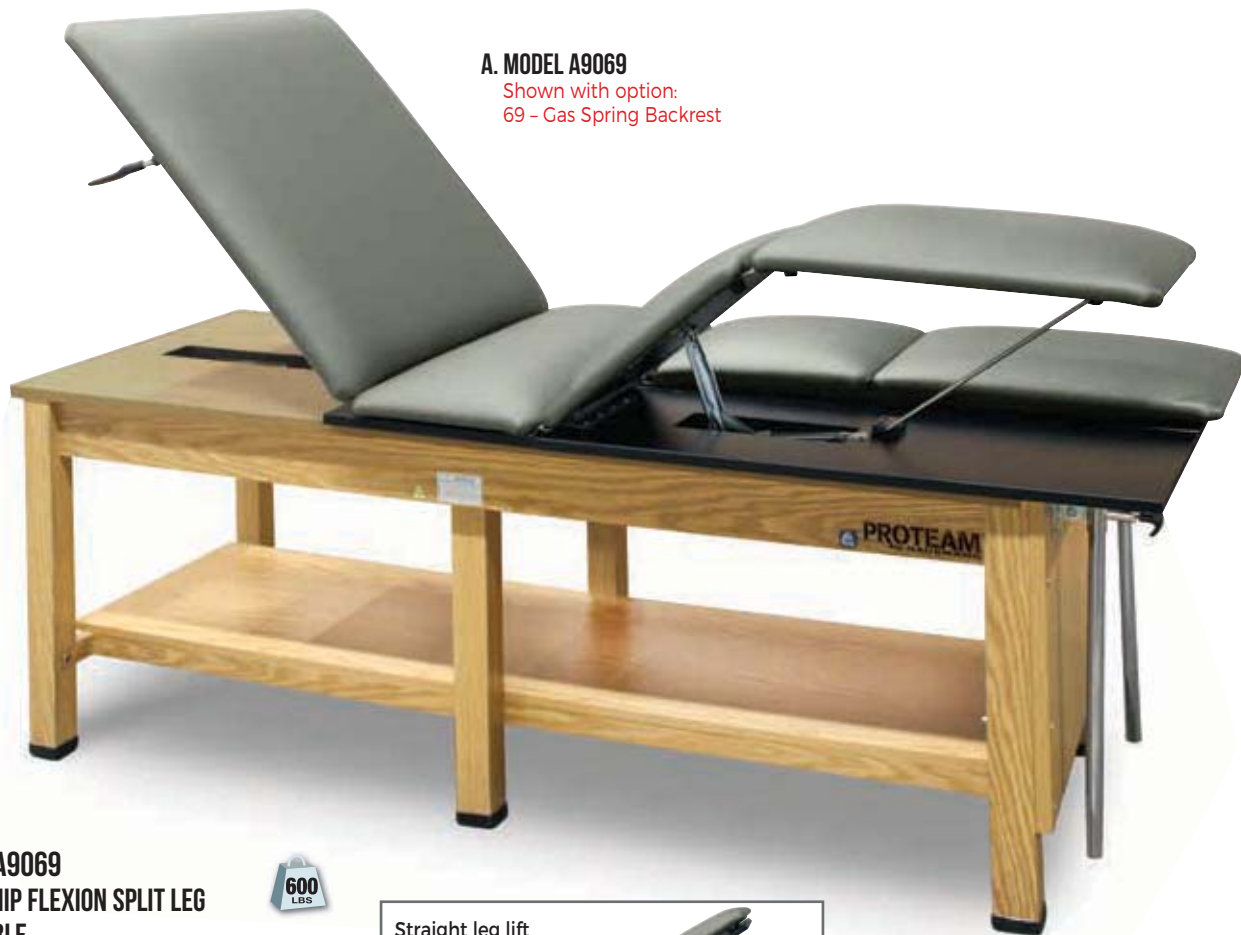

A. MODEL A9069
Shown with option:
69 - Gas Spring Backrest

A. MODEL A9069
KNEE AND HIP FLEXION SPLIT LEG
SIX LEG TABLE



- High-pressure laminate legs, apron, and H-Brace.
- Laminate shelf with (2) long stretchers.
- New enhanced hardware system
- Legs have protective black vinyl scuff caps.

MODEL	LENGTH	WIDTH	HEIGHT
A9069	78"	30"	32"



Straight leg lift

COMMON FEATURES

KNEE AND HIP FLEXION SPLIT LEG TABLES - MODELS A9069, A9070, A9071:

- Extremely versatile and functional split leg design.
- Each padded leg rest can be adjusted and locked into desired angle up to 45° with spring-loaded lock-in lever.
- Each padded leg rest can be adjusted with hip and knee joints locked into 45° angle with easy to operate hinge mechanism.
- Full plywood subtop for added strength.
- 30" x 78" upholstered top with comfortable 2" thick high-density foam.

COLORS: (SEE INSIDE FRONT COVER)

Laminate - Natural Oak, Wild Cherry or Folkstone Gray (Folkstone - A9070, A9071 only)

Upholstery - 10 Pro-Form™ vinyl colors

B. MODEL A9070

Shown with option:
69 - Gas Spring Backrest



B. MODEL A9070
KNEE AND HIP FLEXION SPLIT LEG
OPEN STORAGE TABLE



- Open shelf storage, accessible from both sides of the table.
- Full plywood subtop for added strength.

MODEL	LENGTH	WIDTH	HEIGHT
A9070	78"	30"	32"

C. MODEL A9071

Shown with option:
69 - Gas Spring Backrest



C. MODEL A9071
KNEE AND HIP FLEXION SPLIT LEG
CABINET TABLE



- Six hinged doors with interior shelf offer concealed supply storage.
- Full subtop for increased strength.

MODEL	LENGTH	WIDTH	HEIGHT
A9071	78"	30"	32"

OPTIONS

MODELS A9069, A9070, A9071

*69 - Gas Spring Backrest 0° to 75°

*99-L - Left hand table (A9071 only)

*A946 - (1) Lock/Bolt for Double Doors

*FACTORY INSTALLED

YES! HAUSMANN CAN DO THAT!

Hausmann's top priority is customer satisfaction and takes great pride in the ability to customize products to meet specific needs. Custom fabrication from a rough sketch, modifying existing products, sourcing high-pressure laminate or alternate color vinyl are routine requests handled expertly by Hausmann's team of engineers and product specialists. Hausmann can work with you, from start to finish, to make your concept for a product a reality.

Have an idea for a product? Yes, we can!

Green Bay Packers Taping Station



Design concept based on drawing submitted by the Packers. 3D models and renderings created by Hausmann.



Taping station being pre-assembled in the Hausmann factory.



Finished taping station with custom WilsonArt® Fonthill Pear laminate in the Packers athletic training room.

Washington State University



Football athletic training room shown with custom Nevamar® Washington Apple laminate and Boltaflex® Candy Apple vinyl.

PROTEAM

Custom door and drawer fronts HPL embedded graphics.



Rose-Hulman Institute of Technology



Athletic training room shown with custom laminate side panel on end of taping station.

**A. MODEL A9021
RECOVERY TABLE**



- Foot end of table has a gas-spring elevating leg rest (up to 75°) and a full-extension modality drawer.
- Middle section of table has a side pullout drawer with (4) drying rods.
- Head section of table has (2) hinged doors with interior adjustable shelf offering concealed storage.
- Finished laminate back.
- Table can be used as a traditional treatment table with elevating backrest by reversing the athlete.
- Grommet holes in foot section of table and in black laminate base allow for easy cord management.
- 2" thick high-density foam upholstered tops.
- 3mm high-impact PVC edges on all door and drawer fronts.

COLORS: (SEE INSIDE FRONT COVER)

Laminate - Natural Oak and Wild Cherry

Upholstery - 10 Pro-Form™ vinyl colors

MODEL	LENGTH	WIDTH	HEIGHT
A9021	78"	30"	31"

A. MODEL A9021

Shown as right hand table (standard configuration)
Shown with option: 32 - Pillow



OPTIONS

MODELS A9021, A9075, A9078

- *A945 - Drawer Lock
- *A946 - (1) Lock/Bolt for Double Doors
- *99L - Left Hand Table

*FACTORY INSTALLED



Scan QR code for more information

B. PRO-OPTIONS TABLE



- Designed to allow you to customize to meet your specific needs... it is as easy as 1-2-3.
- Choose your cabinet style - open cabinets on both sides of table or cabinets on one side of table with solid back.
- Add optional elevating split leg feature and/or gas-spring backrest.
- Customize each compartment with any of five possible options (some restrictions).
- 2" thick high-density foam upholstered tops.
- 3mm high-impact PVC edges on all doors and drawer fronts.

COLORS: (SEE INSIDE FRONT COVER)

Laminate - Natural Oak and Wild Cherry

Upholstery - 10 Pro-Form™ vinyl colors

MODEL	LENGTH	WIDTH	HEIGHT
A9075	78"	30"	31"
A9078	78"	30"	31"

B. MODEL A9075

Shown with options:
A962 - (2) Doors, A963 - Pass thru drawer
A966 - (3) Drawers, 69 - Gas Spring Backrest, A961 - Split Leg



- STEP 1 - Choose your cabinet style**
(standard configuration is flat top):
- A9075 - Open Cabinet Both Sides†
 - A9078 - Cabinet with Solid Back

STEP 2 - Choose your top options:



69 - Gas Spring Backrest, 0° to 75°



A961 - Elevating Split Legs

STEP 3 - Customize your compartments with any of the following options
(standard compartment configuration is open with (1) adjustable shelf)

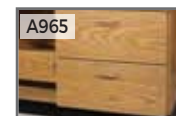

- A962 - Double Doors (includes (1) adjustable shelf)
- A963 - Pass-Thru Modality Drawer (A9075 only - includes 2 grommets for electrical cord management)
- A964 - Modality Drawer (A9078 only - includes 2 grommets for electrical cord management)
- A965 - 2-Drawers†
- A966 - 3 Drawers†

† NOTES (for A9075 Open Cabinet Table)

- Head section of table has offset support (not open pass-thru compartment - only option available is A962 Double Doors).
- If A965 or A966 Drawer option is selected, opposite side will be solid panel.

SPECIALTY TREATMENT TABLES

A. MODEL 7650



PORTABLE TREATMENT/SIDELINE TABLE

- 2 1/2" thick multi-layered semi-firm foam.
- Comfortable PVC-free heavy-weight urethane upholstery.
- Lightweight aluminum frame weighs only 30 lbs.
- Push-button height adjustment.
- Includes adjustable face cradle with ultra soft face cushion, arm sling, and carry bag with shoulder strap.
- Spacious 73" long x 28" wide top.
- Height adjustable from 24" to 32".
- Removable 2" Turf Pad (Set of 4) included for outdoor use.



A. MODEL 7650-751



Removable Turf Pad

Carrying Case

MODEL	COLOR
7650-751	Black PVC-Free Urethane
7650-752	Blue PVC-Free Urethane



B. MODEL 4082

"Pad On"– It's a Treatment Table
Shown with optional #35 pillow



Model 4082
"Pad Off"– It's a Desk



B. MODEL 4082 COMBINATION TREATMENT/ WORK TABLE/DESK



- Dual-purpose – it's a treatment table or a desk. Ideal for schools or clinics.
- 2" thick removable reversible urethane foam pad with nylon reinforced vinyl cover.
- Top pad has straps and can hang vertically on table when not in use.
- Folkstone Gray high pressure laminate sub-top with black 3mm edging.
- Long stretcher offset to the back for easy access when sitting.
- Pad is Blue on one side and Gray on reverse side with 2" Gray border.
- Custom laminate and upholstery color choices available for contract orders of 10 or more tables.

MODEL	LENGTH	WIDTH	HEIGHT
4082	72"	24"	32"

OPTIONS

FOR MODELS 4082, 4075

- *00 – Special Table Height (for 4082 only)
- *04 – Table Safety Strap
- *07 – Nose Cutout (for 4075 only)
- 27 – Paper Dispenser & Cutter Combo
- 32 – Pillow, full size
- 35 – Pillow, small

*FACTORY INSTALLED

C. MODEL 4075



Model 4075 (folded)

C. MODEL 4075 WALL FOLDING TREATMENT/CHANGING TABLE



- Fold-away design saves floor space.
- 2" high-density foam upholstered top.
- Sturdy, floor-supported wall mounting plate for added strength.
- (2) folding high pressure laminate legs.
- Projects only 8" when folded.
- Wall fasteners not included.
- Natural Oak laminate
- 10 Pro-Form™ vinyl upholstery colors.

MODEL	LENGTH	WIDTH	HEIGHT
4075	72"	24"	31"

A. MODEL 4061

A. MODEL 4061
TWO-PERSON TAPING TABLE /
CONVERTIBLE TREATMENT TABLE



- Solid (1) piece construction (not modular).
- (2) Padded taping sections 26" wide x 34" deep x 36" high with (1) removable middle top pad.
- Just add middle pad to convert taping table into a treatment table.
- (3) Storage sections with oak laminate interiors and shelf.
- (1) Center drawer on nylon rollers.
- Doors have concealed, adjustable, self-closing Euro-hinges.
- Comfortable 2" thick high-density foam tops.
- 3mm high impact PVC edges on all door and drawer fronts.

COLORS: (SEE INSIDE FRONT COVER)

Laminate - Natural Oak

Upholstery - 10 Pro-Form™ vinyl colors

MODEL	LENGTH	WIDTH*	HEIGHT
4061	74"	34"	36"

*width of cabinet is 30"



Shown as Treatment Table with middle pad in place

OPTIONS

MODELS 4061, 4062

*A945 - Drawer Lock

*A946 - (1) Lock/Bolt for Double Doors

*FACTORY INSTALLED

B. MODEL 4062
CONVERTIBLE TAPING BENCH/
TREATMENT TABLE



- Multipurpose table functions both as a taping bench with backrest and as a treatment table.
- To use as a taping bench, raise the gas-spring padded backrest up to 75° with recessed control handles on each side of the table.
- Just lower the backrest and the table quickly converts into a full-length treatment table.
- Convenient front full extension pullout for taping supplies.
- Doors have concealed, adjustable, 110° self-closing Euro-hinges.
- (2) 21"W x 24"D open storage sections with adjustable shelves allow access from either side of the table.
- 2" thick high-density foam tops in (3) sections - 32"L seating section, 30"L elevating middle section, and 15"L head section.
- 3mm high impact PVC edges on all door and drawer fronts.

COLORS: (SEE INSIDE FRONT COVER)

Laminate - Natural Oak

Upholstery - 10 Pro-Form™ vinyl colors

MODEL	LENGTH	WIDTH	HEIGHT
4062	78"	27"	34"

B. MODEL 4062





COMMON FEATURES

S&W TREATMENT TABLES:

- Natural wood finish is standard on all S&W Tables.
- H-Brace Tables have triple-bolted, solid hardwood legs.
- Cabinet tables are quality hardwood plywood and veneer construction.
- Extra-firm 2" high-density foam tops with rounded corners for comfort.



COLORS: (SEE INSIDE FRONT COVER)

Upholstery - 10 Pro-Form™ vinyl colors



MODEL ATT2472

MODEL	LENGTH	WIDTH	HEIGHT
ATT2472	72"	24"	31"
ATT2478	78"	24"	31"
ATT2772	72"	27"	31"
ATT2778	78"	27"	31"
ATT3072	72"	30"	31"
ATT3078	78"	30"	31"

OPTIONS

AFW - Finished Wood Shelf

AU - Upholstered Shelf

27 - Paper Dispenser/Cutter Combo

***69** - Gas Spring Backrest 0° to 75°
(N/A on 24"W Tables)

***A946** - (1) Lock/Bolt for Double Doors

***FACTORY INSTALLED**



MODEL ATT2772

Shown with option:
AU - Upholstered Shelf

A. MODEL ATT314

SPECIAL FEATURES:

- Four door cabinet with center divider and one adjustable shelf on each side.
- Leg levelers for uneven floors.
- Satin finish wire pulls.



MODEL	LENGTH	WIDTH	HEIGHT
ATT314	72"	30"	31"

B. MODELS ATT385, ATT386

SPECIAL FEATURES:

- Includes 30" long Gas Spring Backrest, 0° to 75°, as standard feature.
- Includes full-width AU upholstered shelf.



MODEL	LENGTH	WIDTH	HEIGHT
ATT385	72"	30"	31"
ATT386 (not shown)	78"	30"	31"



AFW Wood Shelf

AU Upholstered Shelf

A. MODEL ATT314

Shown with option:
69 - Gas Spring Backrest



B. MODEL ATT385

Shown with standard
69 - Gas Spring Backrest





**A. MODEL AT810
WHIRLPOOL TABLE**



- Natural finish hardwood table with Oak HPL marine grade plywood top and steps.
- Water-resistant urethane finish.
- Leg levelers for uneven floors.
- 47" wide x 32" deep available for 22", 24" and 26" whirlpools.
- Please specify manufacturer, model number and size and height of tank when ordering. Custom sizes available. We add approximately 1 1/4" to the width of the tank as a clearance factor.

MODEL	LENGTH	WIDTH	HEIGHT
AT810	47"	32"	Variable

O/A footprint including steps is 56"L x 42"W



**MODEL AT815
WHIRLPOOL TABLE WITH CABINET**



- Same as AT810 but includes 2 shelf cabinet on backside of table as shown on Model AT825.
- Shelf dimensions are 35"W x 12"H x 9"D.

MODEL	LENGTH	WIDTH	HEIGHT
AT815 (not shown)	47"	32"	Variable

O/A footprint including steps is 56"L x 42"W



**MODEL AT820
WHIRLPOOL TABLE FEATURING
STARBOARD® ST TOP**



- Same as AT810 but with StarBoard® ST top and steps.
- StarBoard® ST is a high-density polyethylene sheet which is waterproof and scratch-resistant and features a textured surface.
- Standard color is Sansshade.

MODEL	LENGTH	WIDTH	HEIGHT
AT820 (not shown)	47"	32"	Variable

O/A footprint including steps is 56"L x 42"W

**B. MODEL AT825
WHIRLPOOL TABLE FEATURING
STARBOARD® ST TOP WITH CABINET**



- Starboard® ST top and steps standard.
- StarBoard® ST is a high-density polyethylene sheet which is waterproof and scratch-resistant and features a textured surface.
- Standard color is Sansshade as shown.
- Includes 2 shelf cabinet on backside of table.

MODEL	LENGTH	WIDTH	HEIGHT
AT825	47"	32"	Variable

O/A footprint including steps is 56"L x 42"W



B. MODEL AT825



A. MODEL 4719
Shown with option:
27 - Paper Dispenser & Cutter



B. MODEL 4718
Shown with option:
69 - Gas Spring 30"L Backrest
A905 - Emboss Logo

C. MODEL 4710
ALL-PURPOSE HI-LO
TREATMENT TABLE



- Electric motorized height adjustment from 18 1/2" (wheelchair height) to 35" high.
- "Hands-free" foot control operation.
- Adjustable 26" long headrest has dual gas spring operation and single lever activation.
- Headrest raises to 83°. Lowers to 40° below flat.
- Base has 4 1/2" clearance for most patient hoists.
- Steel frame with powder coated cream finish.
- Stocking upholstery vinyl color is Dove Gray.
- Retractable locking casters with lever activation.
- Includes paper dispenser and cutter.
- 110V, 60 Hz, 3.15 Amps.

MODEL	LENGTH	WIDTH	HEIGHT
4710	78"	28"	18 1/2" - 35"



C. MODEL 4710

COMMON FEATURES

POWER TABLES –
MODELS 4718, 4719:

- Heavy-duty, motorized hydraulic Hi-Lo system with 10" lift stroke.
- Electrically activated hydraulic cylinders are built into (4) corner telescoping legs.
- Legs are black powder-coated and equipped with levelers for uneven floors.
- "Hands-free" foot control operation.
- Vinyl upholstered tops with 2" high-density urethane foam.
- Hospital grade plug.
- 110V, 60Hz, 2.4 amps.
- Available option: 27 - Paper Dispenser & Cutter.

COLORS: (INSIDE FRONT COVER)
Upholstery - 10 Pro-Form™ vinyl colors.

A. MODEL 4719   
HI-LO POWER PLINTH TABLE WITH SHELF

SPECIAL FEATURES:

- Bariatric 600 lb. lift capacity.
- Motorized table elevates from 27" to 37" high.
- Oak laminate apron with black laminate storage shelf.

MODEL	LENGTH	WIDTH	HEIGHT
4719	78"	30"	27"-37"

B. MODEL 4718 
HI-LO "EXTRA LONG" TRAINERS TABLE

SPECIAL FEATURES:

- Motorized table elevates from 27" to 37" high.
- Extra-long 84" x 30" wide upholstered top is ideal for taller athletes.
- Fully enclosed Oak laminate cabinet with (4) drawers and sliding door storage.
- Optional #69 30"L Gas Spring Backrest.

MODEL	LENGTH	WIDTH	HEIGHT
4718	84"	30"	27"-37"

COMMON FEATURES

POWERMATIC® TREATMENT TABLES — MODELS 4746, 4747, 4750, 4756, 4757 :



- The Powermatic® electro-mechanical drive mechanism provides an infinite number of height positions.
- Patients can mount or dismount without a footstep. You can work faster and more efficiently without back strain or fatigue.
- 2" High-density urethane foam vinyl top.
- "Hands free" foot control operation.
- Includes Paper Dispenser and Cutter.
- Hospital grade plug.
- 110V, 60Hz, 3.5 Amps. U.L. Listed.
- New contoured black base plate with (4) levelers and satin aluminum trim.

COLORS: (INSIDE FRONT COVER)

Laminate - Folkstone Gray

4746, 4747 only: choice of any high pressure laminate solid color or woodgrain

Upholstery - 10 Pro-Form™ vinyl colors.



A. MODEL 4746

A. MODEL 4746 POWERMATIC® TREATMENT TABLE WITH GAS-SPRING BACKREST



SPECIAL FEATURES:

- Gas-spring pneumatic 30" backrest elevates to 75° with new lever control on both sides.
- Power height adjusts from 26" to 38".
- (2) laminate drawers on nylon rollers.
- Hinged door storage compartment.
- Shipped fully assembled.

MODEL	LENGTH	WIDTH	HEIGHT
4746	76"	27"	26"-38"

MODEL 4747 (not shown) POWERMATIC® TREATMENT TABLE WITH POWER BACKREST

- Same as Model #4746 except power 30" backrest can be elevated automatically to 75° with foot control.

MODEL	LENGTH	WIDTH	HEIGHT
4747	76"	27"	26"-38"

OPTIONS

FOR MODELS 4746, 4747, 4750, 4756, 4757:

- *04 - Table Safety Strap
- *07 - Nose Cutout (4750 only)
- *15 - (1) Safety Rail (4746, 4747 only)
(Order [2] #15 if both sides)
- 32 - Pillow, full size
- 35 - Pillow, small
- *99L - Left Hand Table Model

*FACTORY INSTALLED



B. MODEL 4750

B. MODEL 4750 POWERMATIC® TABLE WITH FLAT TOP



SPECIAL FEATURES:

- Power height adjustment from 19" wheelchair height to 31" high.

MODEL	LENGTH	WIDTH	HEIGHT
4750	76"	27"	19"-31"



C. MODEL 4756

C. MODEL 4756 POWERMATIC® TABLE WITH GAS-SPRING BACKREST

SPECIAL FEATURES:

- Power height adjustment from 19" wheelchair height to 31".
- Gas-spring pneumatic 30" backrest elevates to 75° with new lever control on both sides.

MODEL	LENGTH	WIDTH	HEIGHT
4756	76"	27"	19"-31"

MODEL 4757 (not shown) POWERMATIC® TABLE WITH POWER BACKREST

- Same as Model 4756 except Power 30" backrest elevates to 75° with foot control.

MODEL	LENGTH	WIDTH	HEIGHT
4757	76"	27"	19"-31"

A. MODEL 6071



B. MODEL 6074



COMMON FEATURES

HI-LO SECTIONAL TABLES –
MODELS 6071, 6074:



- "Hands-free" foot control operation.
- Open base allows closer access to patient.
- Powder coated heavy duty steel frame
- Quiet and stable, single column actuator adjusts from 24" to 33" H.
- Single column actuator saves space, no top shift when elevating.
- Hospital grade power cord.
- 100V-240V, 50/60Hz, 3.15 Amps

A. MODEL 6071 2-SECTION HI-LO TREATMENT TABLE WITH ARMRESTS AND ADJUSTABLE GLIDES

SPECIAL FEATURES:

- 2-Section Power Table can be used for a wide variety of purposes.
- Folding armrests for extra patient comfort.
- Includes paper dispenser (factory installed).
- 2-Section top is 75" L x 28" W with 2" thick high density foam.
- Head/Backrest is 25" L x 28" W & elevates up to 67° with dual release friction lock.
- Adjustable glides allow for easy leveling.
- Agate Blue vinyl upholstery.

B. MODEL 6074 3-SECTION MOBILE HI-LO TREATMENT TABLE WITH LOCKING CASTERS



SPECIAL FEATURES:

- 3-Section Power Table can be used for a wide variety of purposes.
- (4) 3" diameter, swiveling and locking casters.
- 3-Section top is 78" L x 28" W with 2" thick high density foam.
- Contoured face/nose cutout in head section.
- Head section, 19" L x 28" W adjusts from flat to 90° below horizontal.
- Middle section, 21" L x 28" W is stationary.
- Leg/Backrest section, 38" L x 28" W, elevates up to 70° with dual release friction lock.
- Agate Blue vinyl upholstery.

MODEL	LENGTH	WIDTH	HEIGHT
6071	75"	28"	24"-33"

MODEL	LENGTH	WIDTH	HEIGHT
6074	78"	28"	24"-33"

C. MODEL 6053



C. MODEL 6053 3-SECTION HI-LO MULTI-POSITION TREATMENT TABLE

- Multi-position table can be used for a wide variety of therapy and treatment functions.
- 76" L x 27" W 3-section 1 1/2" thick high density gray vinyl top features contoured face/nose cutout in head section.
- Motorized height adjustment from 19" wheelchair height to 37" H.
- "Hands-free" foot control operation.
- Adjustable head section, 15" x 27", raises up to 45° and lowers down to 90° below horizontal.



- 22" L x 27" W Middle seat section is stationary
- 39" L x 27" W Leg/Backrest section raises easily up to 73° with sturdy friction locking device and dual release handles.
- Top sections have welded steel support frames.
- Includes (4) 3" diameter swiveling casters with locking brakes.
- 110V, 60 Hz, 1.8 amps. U.L. Listed.

MODEL	LENGTH	WIDTH	HEIGHT
6053	76"	27"	19"-37"

COMMON FEATURES

MAXIMUM VALUE EXAM TABLES - SERIES 4420, 4421, 4423, 4424:



- Removable vinyl top pad attached with VELCRO® brand fasteners.
- Contoured padded head section.
- Backrest is pneumatic air-spring with dual adjustment controls from 0° to 75°.
- Built-in front safety tread footstep.
- Sliding legrest extension with removable pad attached with VELCRO® brand fasteners.
- Heavy duty concealed stirrups adjust in length and are laterally adjustable in (4) positions. Vinyl coated heelrests.
- Paper dispenser and paper cutter.
- Hospital grade duplex outlet.
Note: LD models do not have outlet.
- Black laminate base with leveling legs.

COLORS: (SEE INSIDE FRONT COVER)

Laminate - Folkstone Gray

Upholstery - 10 Pro-Form™ vinyl colors



Full-comfort pad with VELCRO® brand fasteners detaches easily for cleaning or replacement.



A. MODEL 4423

OPTIONS

FOR SERIES 4420, 4421, 4423, 4424

*15 - (1) Safety Rail (Order [2] if both sides)

*091 - Pelvic Tilt (Controls on both sides)

*097 - Stainless Steel Pan & Cutout

*FACTORY INSTALLED

A. SERIES 4423, 4424

SPECIAL FEATURES:

- (2) Drawers in front and (3) drawers on side as shown.

MODEL	LENGTH	WIDTH	HEIGHT
4423	55" - 71"	26"	33"
4423-LD	Same but less Duplex outlet		
4424	Left Hand Table		
4424-LD	Same but less Duplex outlet		

B. SERIES 4420, 4421

SPECIAL FEATURES:

- (2) Drawers in front and (1) door on side with shelf as shown.

MODEL	LENGTH	WIDTH	HEIGHT
4420	55" - 71"	26"	33"
4420-LD	Same but less Duplex outlet		
4421	Left Hand Table		
4421-LD	Same but less Duplex outlet		



B. MODEL 4420

Shown with option:
097 - Stainless Steel Pan

Metal Paper Dispenser

Upholstered, removable top pad

Pneumatic Air Spring Backrest

Slide-Out leg rest with pad, 21" wide by 16" deep

4-position laterally adjustable stirrups, concealed when not in use

Stainless steel irrigation pan (optional)

Storage cabinet with shelf

Hospital grade duplex outlet (not supplied on "LD" models)

Built-In Safety-Tread Foot Step, 21" wide x 13" deep x 7¾" high



A. MODEL 1440-57-113

A. SERIES 1440 DUAL LIFT POWERMATIC® MAT PLATFORMS



- Power height adjustment from 19" wheelchair access height to 28"H.
- Two direct drive, synchronized lift mechanisms for unsurpassed power.
- Black laminate base with satin aluminum trim and levelers.
- Tear resistant, seamless nylon-reinforced vinyl upholstered top with 2" high-density urethane foam padding for comfort and rounded corners for safety.
- "Hands-free" foot control.
- Hospital grade plug.
- 110V, 60Hz, 2.8 Amps. U.L. Listed

MODEL	WIDTH	LENGTH	HEIGHT
1440-46-113	4'	6'	19"- 28"
1440-46-119	4'	6'	19"- 28"
1440-47-113	4'	7'	19"- 28"
1440-47-119	4'	7'	19"- 28"
1440-57-113	5'	7'	19"- 28"
1440-57-119	5'	7'	19"- 28"
1440-68-113	6'	8'	19"- 28"
1440-68-119	6'	8'	19"- 28"

You must specify upholstery color with order.

UPHOLSTERY - 113 BLUE OR 119 GRAY

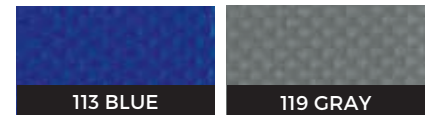

SPECIAL ORDER TOP COLORS

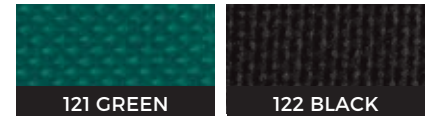

B. SERIES 1441 ECONO ELECTRIC HI-LO MAT PLATFORMS



- Power height adjustment from 20" wheelchair height to 29"H.
- Two direct drive, synchronized lift mechanisms for greater power. 600 lbs. patient lift capacity.
- Tear resistant, seamless nylon-reinforced vinyl upholstered top with 2" high-density urethane foam padding for comfort and rounded corners for safety.
- Sturdy black laminate base with leveling legs.
- "Hands-free" foot control.
- Hospital grade plug.
- 110V, 60Hz, 1.3 Amps.

MODEL	WIDTH	LENGTH	HEIGHT
1441-46*	4'	6'	20"-29"
1441-47*	4'	7'	20"-29"
1441-57*	5'	7'	20"-29"

You must specify upholstery color with order.

B. MODEL 1441-47-119





A. MODEL 1427-57-121

COMMON FEATURES

MAT PLATFORMS —

SERIES 1427, 1428, 1429:



- Extremely stable lift system elevates from 20" wheelchair height to 30" high.
- "Hands-free" foot control.
- Seamless nylon-reinforced vinyl is wear and tear resistant.
- 2" High-density urethane foam vinyl top.
- Steel frame and 4 corner legs have durable black powder coat finish.
- Legs have levelers for uneven floors.
- 4-Leg "open" design is patient sling-lift accessible on all four sides.
- Hospital grade plug.

COLORS: (SEE PAGE 24)

Upholstery – 113 Blue, 119 Gray, 121 Green, 122 Black

You must specify upholstery color with order.

A. SERIES 1427 BARIATRIC MAT PLATFORMS



SPECIAL FEATURES:

- Electrically activated hydraulic cylinders are built into each (4) corner steel leg.
- Motorized lift system can securely lift 750 lbs. from 20" wheelchair height to 30" high.
- "Hands-free" foot control operation.

MODEL	WIDTH	LENGTH	HEIGHT
1427-46*	4'	6'	20"-30"
1427-47*	4'	7'	20"-30"
1427-57*	5'	7'	20"-30"
1427-68*	6'	8'	20"-30"

B. SERIES 1428 ELECTRIC HI-LO MAT PLATFORM WITH POWERBACK



SPECIAL FEATURES:

- Electrically activated hydraulic cylinders built into each of 4 corner legs with 750 lbs. patient weight capacity.
- Wheelchair Accessible - Elevates smoothly from 21" wheelchair height to 31" H.
- Electric backrest can lift and elevate the back of an immobile patient. Backrest lift capacity is 400 lbs. Backrest adjusts from 1° to 70°.
- "Hands free" foot control operation for backrest and height adjustment.
- Ready for Use - Ships fully assembled ready for use. Just Plug it in and Good to Go!

MODEL	WIDTH	LENGTH	HEIGHT
1428-47	4'	7'	21"-31"
1428-57	5'	7'	21"-31"

B. MODEL 1428-47-119



Series 1428
Electric
Backrest



C. MODEL 1429-68-113

C. SERIES 1429 BARIATRIC 1100 LB. CAPACITY HEAVY-DUTY MAT PLATFORM



SPECIAL FEATURES:

- Electrically activated hydraulic cylinders are built into each (4) corner steel leg.
- Motorized lift system can securely lift 1100 lbs. from 20" wheelchair height to 30" high.
- Static load tested to 4400 lbs.
- Seamless nylon reinforced vinyl is tear resistant.
- Plywood reinforced subtop for added strength.

MODEL	WIDTH	LENGTH	HEIGHT
1429-57	5'	7'	20"-30"
1429-68	6'	8'	20"-30"

COMMON FEATURES

UPHOLSTERED MAT PLATFORMS —
MODELS 1412, 1420, 1421:



- 2" Thick high-density urethane foam.
- Upholstered in seamless heavy duty, tear-resistant nylon-reinforced vinyl.
- High pressure laminate finish on all exterior surfaces.
- 18" height is convenient for therapist and wheelchair accessible for patient.

COLORS:

Laminate - 346 Natural Oak or
927 Folkstone Gray

Upholstery - 4 nylon-reinforced vinyl colors
You must specify laminate and upholstery
color with order.

UPHOLSTERY - 113 BLUE OR 119 GRAY

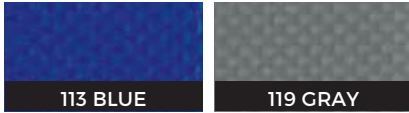

SPECIAL ORDER TOP COLORS



A. MODEL 1412-47-346-122

A. SERIES 1412 UPHOLSTERED MAT PLATFORMS

SPECIAL FEATURES:

- All models have (6) legs for increased strength and stability (1412-46 has 4 legs).

MODEL	WIDTH	LENGTH	HEIGHT
1412-46	4'	6'	18"
1412-47	4'	7'	18"
1412-57	5'	7'	18"
1412-68	6'	8'	18"

B. MODELS 1420, 1421 SPACE SAVER MAT PLATFORM

SPECIAL FEATURES:

- Fold-away design saves floor space.
- Sturdy, floor-supported mounting plate.
- Three folding high pressure laminate legs.
- Wall fasteners not included.

MODEL	WIDTH	LENGTH	HEIGHT
1420	4'	7'	18"
1421	5'	7'	18"

(projects 8" when closed)



B. MODEL 1420-346-119

C. MODELS 1418, 1419 BARIATRIC SPACE-SAVER THERAPY PLATFORM



- Six high pressure laminate legs.
- 2" thick high-density foam top.
- 1000 lbs. patient weight capacity.
- Laminate: 346 Natural Oak (shown) or 927 Folkstone Gray.
- Upholstery: Choice of (10) Pro-Form™ Vinyl Colors.

MODEL	LENGTH	WIDTH	HEIGHT
1418	78"	30"	18"
1419	78"	36"	18"



C. MODEL 1418

**A. OPTION A931
PROPRINT™ GRAPHIC
Shown on 1441-47**



**A. OPTIONS A931, A932, A933
PROPRINT™ GRAPHIC ON MAT PLATFORM**

- Your team logo or graphics are digitally printed on mat vinyl using PROPRINT™ technology.
- Ultra-durable imaging uses premium ink and an unlimited color selection and gradient shading.
- Logo can be printed vertically or horizontally up to the size of the mat platform.
- Seamless nylon-reinforced vinyl is wear and tear resistant and available in 14 colors for logos on 4'x6' and 4'x7' mat platforms.
- Logos on 5'x7' and 6'x8' mat platforms are fully printed on white seamless nylon-reinforced vinyl; smaller mat platforms can also be fully printed using this same technology.
- Please note that fully printed mat platforms may be more susceptible to scratches and blemishes, particularly on the edges and at the corners.

OPTION	DESCRIPTION
A931	Logo for 4'x6" or 4'x7' mat platform
A932	Logo for 5'x7' mat platform
A933	Logo for 6'x8' mat platform

PROPRINT™ NYLON REINFORCED VINYL COLOR CHOICES:



**B. SERIES 1425
CRANK HYDRAULIC MAT PLATFORMS**



- Durable, super-strength crank hydraulic system can lift 750 lbs. from 20" wheelchair height to 30" high.
- Easy-to-use hand crank height adjustment with fold away handle.
- Hydraulic cylinders are built into each (4) corner steel leg.
- Seamless reinforced vinyl is tear resistant.
- Steel frame is durable black powder coated finish.
- 2" High-density urethane foam top.
- Legs have levelers for uneven floors.
- 4-Leg "open" design is patient sling-lift accessible on all four sides.

MODEL	WIDTH	LENGTH	HEIGHT
1425-46*	4'	6'	20"-30"
1425-47*	4'	7'	20"-30"
1425-57*	5'	7'	20"-30"
1425-68*	6'	8'	20"-30"

You must specify upholstery color with order.

B. MODEL 1425-68-119

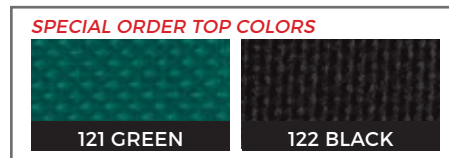

Shown with optional Bolsters (see page 38)

HUGGER WEIGHTS & DUMBBELLS

SERIES 5580 HUGGER® GOLD-LINE WRIST AND ANKLE WEIGHTS



- Vinyl weights color-coded and weight imprinted for ease of use.
- Extra long 17" strap with hook and loop fasteners allows you to double-strap weight in place for added security.
- Heavy-duty stitching assures greater strength and longevity.
- Extra-large brass hanging grommet.
- All weights 6 lbs. and over have (2) grommets & (2) straps with hook and loop fasteners and (6) vertical pockets.
- All weights are filled with smooth non-absorbent steel pellets for comfort.
- Hugger® weights are hygienically sealed in individual plastic protective packages.
- Hugger® weights are sold individually or in sets.



MODEL 5580-1

SERIES 5580 HUGGER® WEIGHTS



MODEL	LBS.	COLOR
5580-05	½	Tan
5580-1	1	Blue
5580-15	1 ½	Olive
5580-2	2	White
5580-25	2 ½	Red
5580-3	3	Gold
5580-4	4	Turquoise
5580-5	5	Black
5580-6	6	Tan
5580-7	7	Blue
5580-75	7 ½	Orange
5580-8	8	Tan
5580-9	9	Green
5580-10	10	Brown
5580-12	12	Black
5580-150	15	Black
5580-200	20	Tan

MODEL 5580-75



Each weight is factory sealed.
All weights are sold individually or in sets.

MODEL 5581 (not shown) SET OF 16 HUGGER® WEIGHTS



Consists of: (2) each of 1 lb., 1 ½ lb., 2 lb., 2 ½ lb., 3 lb., 4 lb., 5 lb. and (1) each of 7 ½ lb. and 10 lb.

MODEL	TYPE
5581	Set of (16) Hugger® Weights

MODEL 5588 (not shown) SET OF 5 HUGGER® WEIGHTS



Consists of: (1) each of 1 lb., 2 lb., 3 lb., 4 lb., and 5 lb.

MODEL	TYPE
5588	Set of (5) Hugger® Weights

VINYL COATED DUMBBELLS



MODEL	LBS.	COLOR
5510-V	1	Pink
5511-V	2	Aqua
5512-V	3	Plum
5513-V	4	Grape
5514-V	5	Teal-Green
5515-V	6	Burnt Orange
5516-V	7	Bluish Green
5517-V	8	Burgundy
5518-V	9	Blue
5519-V	10	Ebony Black

MODEL 5505

Sold as sets or individually



Weight is embossed on each end

MODEL 5502 (not shown) SET OF 6 VINYL DUMBBELLS



MODEL	CONSISTS OF
5502	(2) each 1 lb. through 3 lb.

MODEL 5503 (not shown) SET OF 5 VINYL DUMBBELLS



MODEL	CONSISTS OF
5503	(1) each 1 lb. through 5 lb.

MODEL 5505 SET OF 10 VINYL DUMBBELLS



MODEL	CONSISTS OF
5505	(1) each 1 lb. through 10 lb.

A. MODEL 5555



B. MODEL 5555-100



C. MODEL 5576

All weights, dumbbells and bands must be ordered as accessories.

**A. MODEL 5555
ECONOMY WALL DUMBBELL RACK**



- Black powder coated metal wire rack attaches easily to any wall.
- (10) hooks are graduated in size to hold 1 to 10 lb. vinyl coated dumbbells.

MODEL	HEIGHT	WIDTH	DEPTH
5555	53 ¼"	10"	3 ½"

**B. MODEL 5555-100
ACCESSORIZED WALL DUMBBELL RACK**



CONSISTS OF

(1) 5555 rack, (1) 5505 set of (10) Dumbbells

**C. MODEL 5576
DUMBBELL WAGON**



- Oak laminate finish on all surfaces.
- Upper 34 ½" x 22 ½" tray work surface accommodates up to (20) various size dumbbells.
- Lower storage shelf with vertical divider.
- Can store weights and accessories.
- 3" diameter heavy duty casters.

MODEL	LENGTH	WIDTH	HEIGHT
5576	39"	24"	32"

**MODEL 5576-100
ACCESSORIZED DUMBBELL WAGON**



CONSISTS OF

5576 with (2) 5505 sets of (10) Dumbbells each

D. MODEL 5541

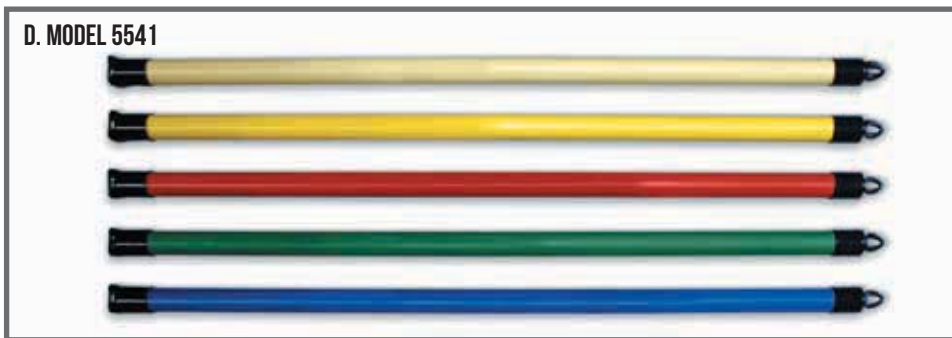

E. MODEL 5545

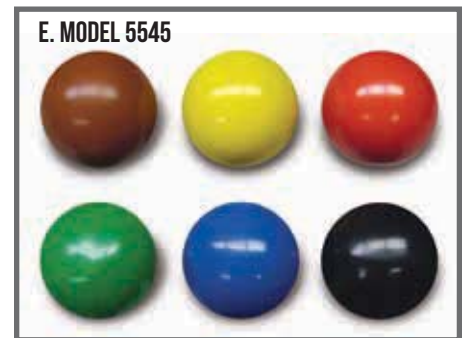

**MODEL 5539 (not shown)
SET OF 3 EXERCISE WEIGHT BARS**



- A series of 1 to 3 lb. easy-to-grip color-coded 36" long weighted bars.
- Ideal for geriatric and nursing home use.
- Features built-in hanger end cap on one end and anti-roll end cap on other end.

MODEL	CONSISTS OF
5539	(1) each 1 lb., 2 lbs., 3 lbs.

**D. MODEL 5541
SET OF 5 EXERCISE WEIGHT BARS**



- A series of 1 to 5 lb. easy-to-grip color-coded 36" long weighted bars.
- Ideal for rehabilitation exercise activity.
- Features built-in hanger end cap on one end and anti-roll end cap on other end.

MODEL	CONSISTS OF
5541	(1) each 1 lb., 2 lbs., 3 lbs., 4 lbs, 5 lbs.

**E. MODEL 5545
"SOFT-BALL" WEIGHTS, SET OF 6**



- Each 5" ball can be gripped with one hand.
- PVC exterior, anti-slip, color-coded, inflatable with sealed weight pellets.

MODEL	CONSISTS OF
5545	(1) each 1.1 lbs., 2.2 lbs., 3.3 lbs., 4.4 lbs, 5.5 lbs., and 6.6 lbs.



A. MODEL 5570



B. MODEL 5565 Front view



MODEL 5565 Reverse view

All weights and dumbbells shown must be ordered as accessories

A. MODEL 5570 WEIGHT RACK



- Almond coated pegboard on both front and back side.
- Natural Oak laminate base and frame.
- Includes (11) pegboard safety hooks.
- 2" diameter swiveling easy-rolling casters.

MODEL	WIDTH	DEPTH	HEIGHT
5570	24"	18"	57"

MODEL 5570-100 ACCESSORIZED WEIGHT RACK



CONSISTS OF

(1) 5570 rack, (1) 5581 Set of (16) Hugger® Weights

B. MODEL 5565 "COMBO" WEIGHT/ DUMBBELL MOBILE RACK



- Almond pegboard panel on front of rack for storage of optional Hugger® Weights, includes (11) hooks.
- Black laminate panel on back equipped with hooks for (20) dumbbells.
- Oak laminate frame & base.
- 3" diameter swiveling, easy-rolling casters.

MODEL	WIDTH	DEPTH	HEIGHT
5565	24"	18"	57"

MODEL 5565-100 ACCESSORIZED COMBO RACK



MODEL CONSISTS OF

5565 Rack, (1) 5581 Set of (16) Hugger® Weights, (2) 5505 Sets of (10) Dumbbells each

MODEL 5571 PEGBOARD HOOKS



- Set of (11) additional Pegboard Hooks with ball tip ends for safety.

MODEL	LENGTH	QUANTITY
5571	4"	11

COMMON FEATURES

LATEX-FREE RESISTIVE EXERCISE BANDS:



- For multi-functional exercise use.
- Bands are 50 yds. long x 4" wide. Supplied in dispensing box.
- Available in (5) color-coded resistance levels.
- Non-slip, non-latex elastomer.
- No powder, no odor.
- Use this clinically tested allergen-free safer alternative.

C. MODEL 5531 SET OF (5) REP BANDS™



Consists of the following:

LEVEL	COLOR
Extra-Light	Peach
Light	Orange
Medium	Green
Heavy	Blue
Extra-Heavy	Plum

C. MODEL 5531



COMMON FEATURES

COMBINATION WEIGHT RACKS – MODELS 5558, 5560: 

- Almond coated pegboard on front of rack for (16) optional Hugger® weights.
- (11) Pegboard safety hooks.
- (10) Dumbbell hooks on left side and (10) hooks on right side (total of 20 hooks). Dumbbells are optional.
- Durable Black laminate finish.
- Base plate has bumper “T” molding on all four sides.
- 3” diameter swiveling, easy-rolling casters.

A. MODEL 5560 MULTI-PURPOSE COMBINATION RACK

SPECIAL FEATURES:

- Built-in dispensers for #5531 set of (5) REP Bands™ (see page 32). Includes scissors.
- Full view distortion-free glass mirror with ANSI “shatter stop” safety backing.

MODEL	WIDTH	DEPTH	HEIGHT
5560	34"	19"	71"

MODEL 5560-100 ACCESSORIZED MULTI-PURPOSE COMBINATION RACK

CONSISTS OF

(1) 5560 Rack, (1) 5581 Set of (16) Hugger® Weights, (1) 5531 Set of (5) REP Bands™, (2) 5505 Sets of (10) dumbbells each

B. MODEL 5558 COMBINATION RACK WITH WHITEBOARD

SPECIAL FEATURES:

- HPL Whiteboard is a nonmagnetic surface and resists scratching.
- 48” high whiteboard offers a large blank space that’s suitable for notes, diagrams, or therapy instructions. Shelf to hold markers and eraser.
- Built-in dispensers for #5531 set of (5) REP Bands™ (see page 32). Includes scissors.

MODEL	WIDTH	DEPTH	HEIGHT
5558	34"	19"	71"

MODEL 5558-100 ACCESSORIZED RACK WITH WHITEBOARD

CONSISTS OF

(1) 5558 Rack, (1) 5581 Set of (16) Hugger® Weights, (1) 5531 Set of (5) REP Bands™, (2) 5505 Sets of (10) dumbbells each



A. MODEL 5560
Front view

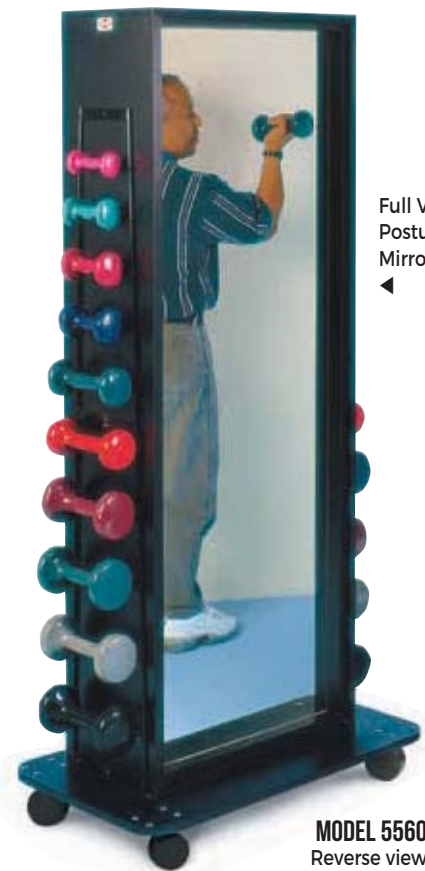

MODEL 5560
Reverse view

Full View
Posture
Mirror
◀

All weights, dumbbells and bands must be ordered as accessories.



B. MODEL 5558
Front view



MODEL 5558
Reverse view

Shelf to hold
markers and
erasers

4-SIDED WEIGHT RACKS

A. MODEL 5557
Front view



MODEL 5557
Reverse view



B. MODEL 5566
Front view



MODEL 5566
Reverse view



A. MODEL 5557
ROTATING WEIGHT RACK



- Rotates 360° for ease of use.
- Built-in dispensers for (5) REP Bands™.
- Hooks for (20) dumbbells.
- Pegboard with (6) hooks for weights.
- Stationary base plate has T-molding.

MODEL	WIDTH	DEPTH	HEIGHT
5557	20"	20"	56"

MODEL 5557-100 ACCESSORIZED RACK



CONSISTS OF

- (1) 5557 Rack, (2) Sets of 5588 Hugger® Weights, (2) 5505 Sets of (10) Dumbbells each, (1) 5531 Set of (5) REP Bands™

B. MODEL 5566
ECONO WEIGHT RACK



- Pegboard with (11) hooks for Hugger® Weights.
- (20) Dumbbell hooks on reverse side of rack.
- Built-in dispensers for (5) REP Bands™.
- Built-in compartment for weight bars.
- Black laminate finish. Base plate has T-molding.
- (4) 3" diameter swiveling casters.

MODEL	LENGTH	DEPTH	HEIGHT
5566	30"	18"	59½"

All weights and dumbbells shown must be ordered as accessories

MODEL 5566-100
ACCESSORIZED RACK



CONSISTS OF

- (1) 5566 Rack, (1) 5581 Set of (16) Hugger® Weights, (2) 5505 Sets of (10) each 1 to 10 lb. dumbbells, (1) Set of 5531 Set of (5) REP™ Bands, (1) 5539 Set of (3) Weight Bars (1 lb, 2 lb, 3 lb)



C. MODEL 5592
Front view



MODEL 5592
Reverse view



C. MODEL 5592
COMPACT WEIGHT RACK



- Pegboard with (11) hooks for Hugger® Weights.
- Built-in dispensers for (5) REP Bands™.
- Hooks to hold (20) dumbbells.
- Storage compartment for weight bars.
- Laminate shelves with (3) plastic storage tubs.
- Black laminate finish. Base plate has T-molding.
- (4) 3" diameter swiveling casters.

MODEL	LENGTH	DEPTH	HEIGHT
5592	32"	24"	68"

MODEL 5592-100
ACCESSORIZED RACK



CONSISTS OF

- (1) 5592 Rack, (1) 5581 Set of (16) Hugger® Weights, (2) 5505 Sets of (10) Dumbbells each, (1) 5531 Set of (5) REP Bands™, (1) 5541 Set of (5) Weight Bars, (1) 5545 Set of (6) "Soft-Ball" Hand Weights

COMMON FEATURES

WEIGHT RACKS - MODELS 5562, 5563:

- Durable Black laminate finish with Oak laminate door and drawer fronts.
- Almond coated pegboard with (11) safety hooks for Hugger® Weights.
- Hooks for (20) dumbbells.
- 3 sets of hooks for optional weight bars.
- Built-in dispensers for optional REP Bands™.
- Full view distortion-free glass mirror with ANSI "shatter stop" safety backing.
- 32" x 32" Base plate has bumper T-molding on all 4 sides.
- 4" dia. twin-wheel, locking casters.



A. MODEL 5562 MEGA-RACK



FEATURES:

- Convenient drop lid work counter with lock.
- (3) 8" high laminate drawers on nylon rollers.
- Built-in dispenser for VELCRO® brand rolls (VELCRO® not included).

MODEL	LENGTH	WIDTH	HEIGHT
5562	32"	32"	72"

MODEL 5562-100 ACCESSORIZED RACK



CONSISTS OF

(1) 5562 Mega-Rack, (1) 5581 Set of (16) Hugger® Weights, (1) 5531 Set of (5) REP Bands™, (2) 5505 Sets of (10) Dumbbells ea., (1) 5539 Set of (3) Weight Bars

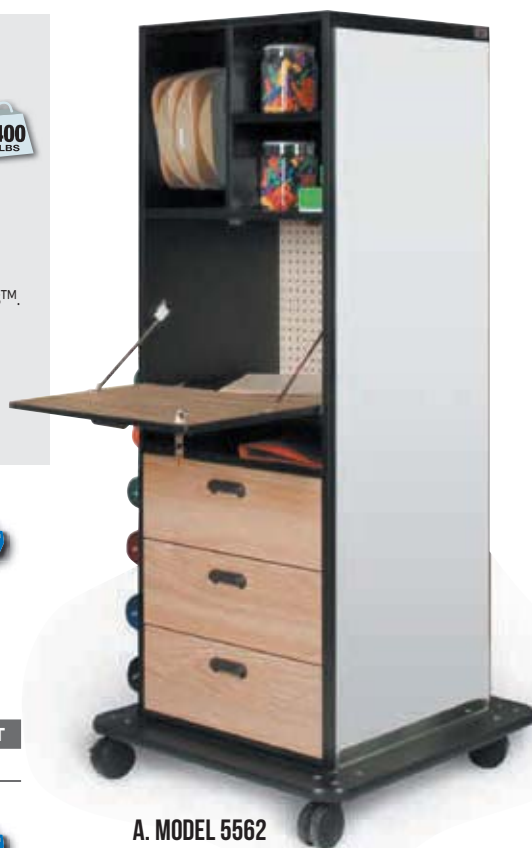

A. MODEL 5562
Front view



MODEL 5562
Reverse view

All weights and dumbbells shown must be ordered as accessories

B. MODEL 5563 "GRAND STAND" STORAGE/WEIGHT RACK

FEATURES:

- Full height 15" wide Oak laminate door with lock and self-closing Euro-hinges.
- Laminate cupboard with (5) adjustable laminate shelves.
- 3" high wire basket at top of rack holds miscellaneous supply items.

MODEL	LENGTH	WIDTH	HEIGHT
5563	32"	32"	72**

*75" Including Wire Basket

MODEL 5563-100 ACCESSORIZED RACK

CONSISTS OF

(1) 5563 Rack, (1) 5581 Set of (16) Hugger® Weights, (1) 5531 Set of (5) REP Bands™, (2) 5505 Sets of (10) Dumbbells ea., (1) 5539 Set of (3) Weight Bars



B. MODEL 5563
Front view



MODEL 5563
Reverse view



A. MODEL 5569
Front view



MODEL 5569
Reverse view

All weights and dumbbells shown must be ordered as accessories



B. MODEL 5556
Front view



MODEL 5556
Reverse view

B. MODEL 5556
MOBILE THERAPY STATION



- Durable laminate finish.
- Top laminate surface is 36" W x 18"D.
- 3mm PVC edging on all exposed edges.
- (5) High impact polystyrene 18" W drawers.
- 18"W Oak laminate door with lock.
- Grab-bar and durable 4" locking casters for mobile use.
- Hooks for (10) dumbbells.
- Almond coated pegboard with (10) 2" safety hooks for Hugger® Weights.

MODEL	LENGTH	DEPTH	HEIGHT
5556	44"	24"	42"

MODEL 5556-100
ACCESSORIZED RACK



- CONSISTS OF**
- (1) 5556 Rack, (2) 5503 Sets of (5) Dumbbells,
 - (1) 5541 Set of (5) Weight Bars, (2) 5588 Sets of (5) Hugger® Weights.

A. MODEL 5569
MULTI-PURPOSE WEIGHT/ STORAGE RACK



- Almond coated pegboard on front of rack for (16) optional Hugger® weights.
- (11) Pegboard safety hooks.
- (10) Dumbbell hooks on left side and (10) hooks on right side (total of 20 hooks). Dumbbells are optional.
- Durable Black laminate finish.
- Base plate has bumper "T" molding on all four sides.
- 3" diameter swiveling, easy-rolling casters.
- Two-door storage cabinet with lock.
- Doors have 165° self-closing Euro-hinges.
- (2) Adjustable shelves and (1) fixed shelf.

MODEL	WIDTH	DEPTH	HEIGHT
5569	30"	24"	61"

MODEL 5569-100
ACCESSORIZED WEIGHT/ STORAGE RACK



- CONSISTS OF**
- (1) 5569 Rack, (1) 5581 Set of (16) Hugger® Weights, (2) 5505 Sets of (10) dumbbells each

(REP Resistive Exercise Bands™ must be ordered as optional accessory. See page 32.)

C. MODEL 6695
(splinting pan not included)



C. MODEL 6695
MOBILE CABINET FOR SPLINTING AND SUPPLIES



- Grab-bar handle for mobility on left side.
- Door cabinet on right with lock.
- High impact polystyrene drawer.
- (3) Vertical cubby sections for splinting material behind hinged door.
- Folkstone Gray laminate.
- Durable dowel and glue construction.
- 4" twin-wheel locking casters.
- Splinting pan is not included.

MODEL	LENGTH	DEPTH	HEIGHT
6695	42"	24"	31"

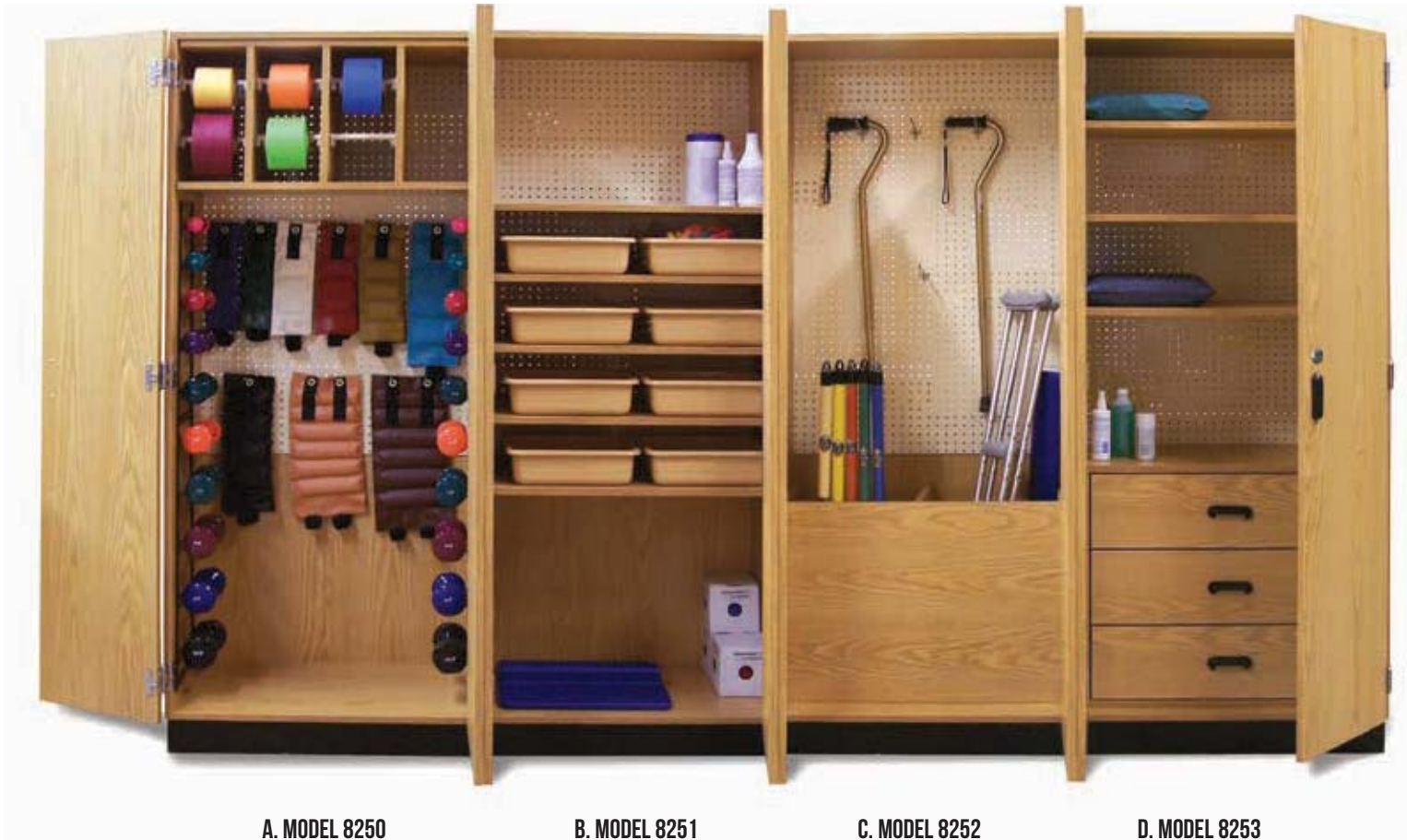

A. MODEL 8250

B. MODEL 8251

C. MODEL 8252

D. MODEL 8253

A. MODEL 8250 CABINET

SPECIAL FEATURES:

- Includes upper dispenser for optional REP Bands™.
- (2) 10-hook metal wire racks on both interior sides to hold (20) optional dumbbells.
- Almond-coated pegboard panel on inside back to hold (16) optional Hugger® Weights. Includes (11) pegboard hooks.
- 3mm PVC high-impact edging on all door fronts.

MODEL	WIDTH	DEPTH	HEIGHT
8250	32"	22"	78"

**MODEL 8250-100
ACCESSORIZED CABINET**

CONSISTS OF

- (1) 8250, (2) 5505 Sets of (10) Dumbbells each (1 to 10 lbs), (1) 5581 Set of (16) Hugger® Weights, (1) 5531 Set of (5) REP Bands™

B. MODEL 8251 CABINET

SPECIAL FEATURES:

- Includes (8) plastic storage tubs (12" x 14" x 4" high) and adjustable laminate shelves.

MODEL	WIDTH	DEPTH	HEIGHT
8251	32"	22"	78"

COMMON FEATURES

THERA-WALL™ THERAPY STORAGE SYSTEM

- MIX & MATCH Modular System. Order 1, 2, 3, 4 or more cabinets to fill any wall space.
- Each oak laminate cabinet module is 32" wide x 22" deep x 78" high and is equipped with (2) Oak laminate hinged locking doors.
- Modular cabinets must be secured to the wall and can be detached and moved if necessary. Wall fasteners not included.
- 3mm PVC high-impact edging on all door fronts.



C. MODEL 8252 CABINET

SPECIAL FEATURES:

- Includes storage bin for optional weight bars and space for canes and crutches.
- Almond pegboard back is equipped with (11) pegboard safety hooks for misc. items.

MODEL	WIDTH	DEPTH	HEIGHT
8252	32"	22"	78"

**MODEL 8252-100
ACCESSORIZED CABINET**

CONSISTS OF

- (1) 8252, (1) 5541 Set of (5) Weight Bars.

D. MODEL 8253 CABINET

SPECIAL FEATURES:

- (3) Laminate storage drawers behind doors.
- (3) Laminate adjustable shelves.

MODEL	WIDTH	DEPTH	HEIGHT
8253	32"	22"	78"

BOLSTERS & PILLOWS

A. Round Bolsters

MODEL 31-99
Shown in 726
American Beauty



MODEL 30-99
Shown in
730 Purple



MODEL 30

A. ROUND BOLSTERS

- High-density urethane foam with vinyl sewn covering.
- Standard stocking color is Medium Blue. 
- Available in 10 standard Pro-Form™ colors at additional charge; order 30-99 or 31-99.

MODEL	LENGTH	DIAMETER
30	24"	6"
31	24"	8"

B. Table Pillows

MODEL 32-723



MODEL 35-729

B. TABLE PILLOWS

- Firm urethane foam. 
- Available in 10 standard Pro-Form™ colors.

MODEL	TYPE	LENGTH	WIDTH	HEIGHT
32	Full Size	22"	14"	3"
35	Small	12"	14"	3"

C. Positioning Pillows



MODEL 36



MODEL 33



MODEL 37



MODEL 39

C. POSITIONING PILLOWS

- Firm high-density urethane foam with vinyl sewn covering. 
- Color for the positioning pillows is Medium Blue.

MODEL	TYPE	LENGTH	WIDTH	HEIGHT
33	Cube	12"	8"	3"
34	Cube	12"	8"	6"
36	20° Wedge	18"	24"	6"
37	20° Wedge	32"	20"	12"
38	Cube w/40° edge	32"	10"	12"
39	Cube w/40° edge	32"	20"	12"

D. "Anti-Slip" Bolsters

MODEL 41



MODEL 42



MODEL 43



D. MODELS 41, 42, 43

"ANTI-SLIP" POSITIONING BOLSTERS

- Firm high-density urethane foam with Medium Blue vinyl cover. 
- Bolsters have "anti-slip" bottom surface that stays in place on mats or tables.

MODEL	TYPE	LENGTH	WIDTH	HEIGHT
41	45° Wedge	16"	8"	8"
42	Half-round	17"	8"	7"
43	20° Wedge	32"	20"	12"

E. MODEL 3003



E. MODEL 3003

MULTI-FUNCTION TWIN WEDGE SET

- Two "twin" high-density urethane foam wedges covered in Medium Blue vinyl. 
- Each 20" x 20" x 10"H wedge has VELCRO® brand fasteners so wedges can be attached back-to-back or put together as a cube.
- Wedges can also be used separately for head, leg or knee support.

MODEL	WIDTH	LENGTH	HEIGHT
3003	20"	20"	10"

COMMON FEATURES

"CHOICE LINE™" AIR-LIFT STOOLS
 MODELS 2153, 2157:

- Hand operated air-spring pneumatic height adjustment.
- 16" diameter seat, 3 1/2" thick foam.
- (5) 2" twin wheel black nylon casters.
- Durable 5-leg, black composite base.

COLORS: (SEE INSIDE FRONT COVER)

Upholstery - 10 Pro-Form™ vinyl colors

A. MODEL 2153 ECONOMY AIR-LIFT STOOL



SPECIAL FEATURES:

- Single lever height control handle.

MODEL	DIAMETER	HEIGHT
2153	16"	20" - 27"
2153-S	16"	17" - 22"



B. MODEL 2157-S



B. MODEL 2157 ECONOMY AIR-LIFT STOOL



SPECIAL FEATURES:

- 360° circular ring control handle.

MODEL	DIAMETER	HEIGHT
2157	16"	20" - 27"
2157-S	16"	17" - 22"

OPTIONS

FOR MODELS 2116, 2151, 2153, 2157

- L - Debossed Logo
 Only available in PROFORM vinyl.

A900 - 6" plate for stool top debossing (required)

FACTORY INSTALLED



Scan for more information



6" Logo Stool Top

C. MODEL 2116 REVOLVING STOOL



- Chrome steel with round foot ring.
- (4) 2" twin wheel black nylon casters.
- Rotate stool top to adjust height.
- Choice of (10) Pro-Form™ vinyl colors.

MODEL	DIAMETER	HEIGHT
2116	16"	18" - 24"

C. MODEL 2116



D. MODEL 2151 HEAVY-DUTY AIR-LIFT STOOL



- Heavy-duty pneumatic lift with "D" chrome control handle.
- 16" diameter seat, 3 1/2" thick foam seat.
- Durable aluminum 5-leg base.
- (5) 2 1/2" twin wheel gray nylon casters.
- Heavy-duty 400 lb. weight capacity.
- Choice of (10) Pro-Form™ vinyl colors.

MODEL	DIAMETER	HEIGHT
2151	16"	20" - 24"

D. MODEL 2151



E. MODEL 2156-707 ECONOMY AIR-LIFT STOOL WITH BACKREST



- Padded backrest, 10" high x 15" wide.
- Air-spring pneumatic height adjustment.
- 360° circular ring control handle.
- Durable 5-leg, black composite base.
- 16" diameter seat, 3 1/2" thick foam.
- (5) 2" twin wheel black nylon casters.
- Black vinyl upholstery.

MODEL	DIAMETER	HEIGHT
2156-707	16"	20" - 27"

E. MODEL 2156-707



COMMON FEATURES

BARIATRIC FOOT STOOLS –
MODELS 2018, 2038



- Heavy duty 1000 lbs. weight capacity.
- Durable, maintenance-free, powder-coated Silver tone finish.
- Footprint of anti-tip base is 25" x 20".

A. MODEL 2018 BARIATRIC XL SAFE STEP

SPECIAL FEATURES:

- Light weight for easy use - ONLY 6 ½ lbs.
- All-aluminum welded construction with anti-tip wide base.
- Anti-slip treaded, extra-large 19" x 15" x 8"H platform with rubber angled leg tips.
- MRI SAFE...non-ferrous and non-magnetic.

MODEL	LENGTH	WIDTH	HEIGHT
2018	19"	15"	8"

A. MODEL 2018



B. MODEL 2038 BARIATRIC XL SAFE STEP WITH HANDRAIL

SPECIAL FEATURES:

- Weighs only 10 ½ lbs. for ease of use.
- Heavy duty tubular aluminum 15" x 19" x 8" high platform with unique anti-tip design.
- 36" high sturdy steel safety handrail snaps in without tools.
- Anti-slip gripper strips & rubber angled leg tips.

MODEL	LENGTH	WIDTH	HEIGHT
2038	19"	15"	36**

*Platform is 8" high

B. MODEL 2038



C. MODEL 2410 NESTED FOOTSTOOLS



- Consists of (4) steps which "nest" together for easy space-saving storage.
- Nested footstools are useful for stepping, crawling or climbing activities.
- Durable Oak laminate wood construction with non-slip matting.

MODEL	LENGTH	WIDTH	HEIGHT
2410 (closed)	20"	16"	8"
Stool Sizes:	20"	16"	8"
	18"	14"	6"
	14"	12"	4"
	12"	9"	2"

C. MODEL 2410



D. MODEL 2010



D. MODEL 2010 BARIATRIC FOOTSTOOL



- Durable 1" bent steel tubing in maintenance-free Silver Vein finish with safety tips.
- 9" high non-skid "anti-slip" ribbed platform.
- Legs are cross-braced to accommodate up to 500 lbs.

MODEL	LENGTH	WIDTH	HEIGHT
2010	14"	10"	9"

E. MODEL 1310 BALANCE ACTIVITY PLATFORM



- Adjustable height 3" stainless steel handrails.
- Black high-pressure laminate with safety treads.

MODEL	WIDTH	DEPTH	HEIGHT
1310	36"	36"	28"-41"

E. MODEL 1310



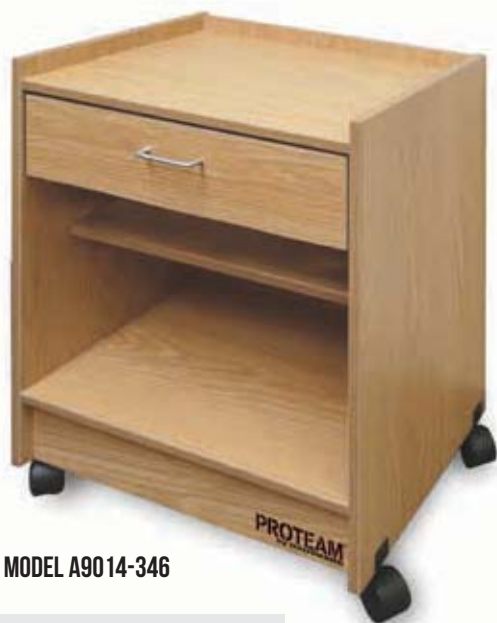

A. MODEL A9014-346



B. MODEL A9015-5904

COMMON FEATURES

PROTEAM CARTS –
SERIES A9014, A9015,
A9016, A9017:



- Maintenance-free laminated surfaces on all cabinet exteriors and interiors.
- Top laminate surface: 23" W x 18" D.
- All cabinets have 3mm PVC edging
- High impact polystyrene drawer interiors with rounded inside corners.
- 4" satin finish wire drawer pulls with oak cabinet, or black nylon wire pulls with gray cabinet.
- 2 ½" twin wheel hooded swivel nylon casters.

COLORS: (SEE INSIDE FRONT COVER)

Laminate – 346 Natural Oak or 5904 Wild Cherry (A9014/A9015 Only). 927 Folkstone Gray & 5904 Wild Cherry available for contract/special orders

A. SERIES A9014 PROTEAM MEGA CART



SPECIAL FEATURES:

- (1) 5 ½" drawer & (1) adjustable shelf.

MODEL	WIDTH	DEPTH	HEIGHT
A9014-346	24 ½"	18 ¾"	32 ½"
A9014-5904	24 ½"	18 ¾"	32 ½"

C. SERIES A9016 PROTEAM MONSTER CART

SPECIAL FEATURES:

- (2) 5 ½" drawers & (1) adjustable shelf.

MODEL	WIDTH	DEPTH	HEIGHT
A9016-346	24 ½"	18 ¾"	38"

B. SERIES A9015 PROTEAM MEGA CART



SPECIAL FEATURES:

- (1) 5 ½" drawer, (2) hinged doors & (1) adjustable shelf.

MODEL	WIDTH	DEPTH	HEIGHT
A9015-346	24 ½"	18 ¾"	32 ½"
A9015-5904	24 ½"	18 ¾"	32 ½"

D. SERIES A9017 PROTEAM MONSTER CART

SPECIAL FEATURES:

- (2) 5 ½" drawers, (2) hinged doors & (1) adjustable shelf.

MODEL	WIDTH	DEPTH	HEIGHT
A9017-346	24 ½"	18 ¾"	38"



C. MODEL A9016-346



D. MODEL A9017-346



A. MODEL A9022-346



B. MODEL A9023-909

COMMON FEATURES

GAME READY™ CARTS – A9022, A9023



- Maintenance-free laminated surfaces on all cabinet exteriors and interiors.
- All cabinets have 3mm high impact PVC edging for increased durability.
- Drawer features 1" opening for easy hose storage and high impact polystyrene interior with rounded inside corners for easy cleaning.
- Crommets on top rear and back for easy electrical cord access.
- 4" satin finish wire drawer pulls.
- 2 ½" twin wheel hooded swivel nylon casters.

COLORS:

Laminate – 346 Natural Oak or 909 Black

A. MODEL A9022 GAME READY™ CART



SPECIAL FEATURES:

- Designed to hold two Game Ready™ units.
- Top surface measures 17" width by 21 ½" depth.
- 4" drawer measures 15 ½" width by 14 ½" depth.
- Bottom pull out features 3 drying racks for Game Ready™ sleeves.

MODEL	WIDTH	DEPTH	HEIGHT
A9022-346	18 ½"	22 ¾"	38 ½"
A9022-909	18 ½"	22 ¾"	38 ½"

B. MODEL A9023 GAME READY™ MEGA CART



SPECIAL FEATURES:

- Designed to hold two Game Ready™ units or one Game Ready™ unit and modality.
- Top surface measures 23" width by 21 ½" depth.
- 4" drawer measures 21 ½" width by 14 ½" depth.
- Bottom pull out features 4 drying racks for Game Ready™ sleeves.

MODEL	WIDTH	DEPTH	HEIGHT
A9023-346	24 ½"	22 ¾"	38 ½"
A9023-909	24 ½"	22 ¾"	38 ½"

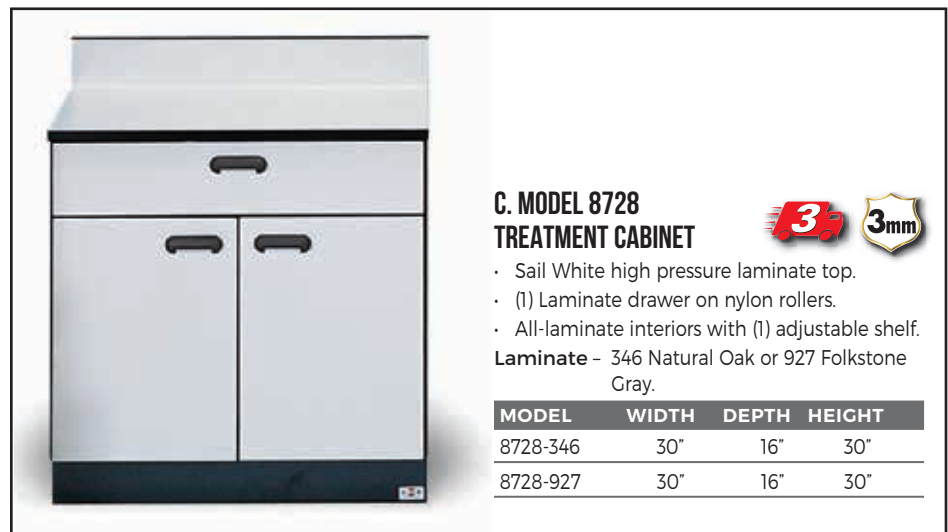

C. MODEL 8728 TREATMENT CABINET



- Sail White high pressure laminate top.
- (1) Laminate drawer on nylon rollers.
- All-laminate interiors with (1) adjustable shelf.

Laminate – 346 Natural Oak or 927 Folkstone Gray.

MODEL	WIDTH	DEPTH	HEIGHT
8728-346	30"	16"	30"
8728-927	30"	16"	30"

COMMON FEATURES

SMART CARTS™ & BEDSIDE CABINETS—
MODELS 9018, 9029, 9038:



- Top laminate surface: 17" W x 17 1/2" D.
- All cabinets have 3mm high impact edging.
- Easy clean polystyrene drawer interiors with rounded inside corners.
- 4" satin finish wire drawer pulls with Oak cabinet, or Black nylon wire pulls with Gray cabinet.
- 2 1/2" twin wheel hooded swivel nylon casters on all mobile models.
- Ships fully assembled.

COLORS:

Laminate – Natural Oak or Folkstone Gray.
Optional 5904 Wild Cherry & 7909 Fusion Maple (9038-20 Only)

A. MODEL 9038-20-346



Close up of 3mm edging.

**CARTS & CABINETS
NOW STANDARD WITH 3MM EDGING**

- High impact edging for increased product durability.
- All edges are trimmed and buffed which eliminates sharp corners.
- All finished edges are 3mm and will not peel.



D. MODEL 9210 MOBILE COMPUTER WORKSTATION



- Portable and efficient mobile workstation with adjustable height top.
- Pneumatic Lift with 360° ring hand control.
- 3mm edging for hi-impact & hi-durability.
- Durable 5-leg, black composite base with locking casters.
- Non-rotating work surface.
- 2" drawer with 3mm high impact edging.
- Plenty of space for portable electronics and equipment.
- 8" height extender available Part 9211 (height 33"-43")

Laminate – Natural Oak, Folkstone Gray, Wild Cherry

MODEL	WIDTH	DEPTH	HEIGHT
9210-346	22"	20"	25"-35"
9210-927	22"	20"	25"-35"
9210-5904	22"	20"	25"-35"



D. MODEL 9210-5904

A. MODEL 9038-20 MOBILE CABINET

SPECIAL FEATURES:

- (2) 5 1/2" drawers & (1) 8 1/2" deep drawer.

MODEL	LENGTH	WIDTH	HEIGHT
9038-20-346	18 1/2"	18 1/2"	30"
9038-20-927	18 1/2"	18 1/2"	30"
9038-20-5904	18 1/2"	18 1/2"	30"
9038-20-7909	18 1/2"	18 1/2"	30"

B. MODEL 9029-24 MOBILE CART

SPECIAL FEATURES:

- Accommodates EKG or compact modality equipment.
- Available only in Folkstone Gray.
- Drop lid door & open storage.

MODEL	LENGTH	WIDTH	HEIGHT
9029-24-927	18 1/2"	18 1/2"	30"

B. MODEL 9029-24-927



MODEL 9018-20 MOBILE CABINET (not shown)

SPECIAL FEATURES:

- (1) 5 1/2" drawer & (1) hinged door.
- Includes (1) 11 1/2" deep adjustable shelf.

MODEL	LENGTH	WIDTH	HEIGHT
9018-20-346	18 1/2"	18 1/2"	30"
9018-20-927	18 1/2"	18 1/2"	30"

C. MODEL 9029-8 MOBILE CABINET

SPECIAL FEATURES:

- (1) 5 1/2" drawer
- Open storage.

MODEL	LENGTH	WIDTH	HEIGHT
9029-8-346	18 1/2"	18 1/2"	30"
9029-8-927	18 1/2"	18 1/2"	30"

C. MODEL 9029-8-927



INSTALLATIONS

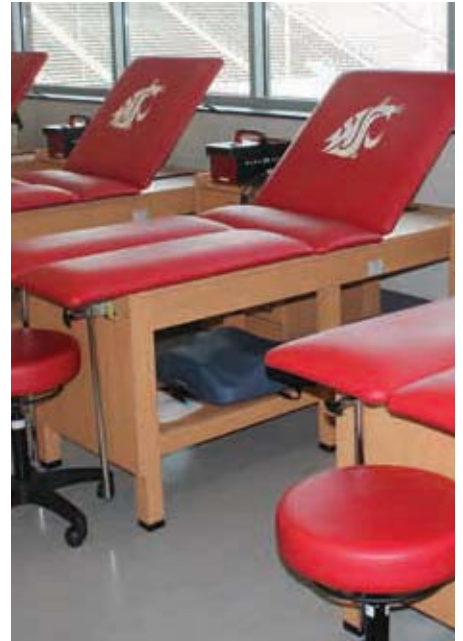



A. MODEL 8248-84-927



B. MODEL 8154-346

COMMON FEATURES

TALL STORAGE CABINETS – MODELS 8154, 8248-84:



- All laminate dowel and glue wood construction. Shipped fully assembled.
- Easy to clean laminate on all exterior and interior surfaces.
- Adjustable laminate shelves.
- Satin finish wire pulls.
- Cabinets & lockers must be secured to the wall and can be detached and moved if necessary. Wall fasteners not included.

COLORS: (SEE INSIDE FRONT COVER)

Laminate – 346 Natural Oak, 927 Folkstone Gray, 5904 Wild Cherry

A. MODEL 8248-84 DOUBLE DOOR STORAGE CABINET

SPECIAL FEATURES:

- (2) doors and (8) adjustable shelves.
- (4) laminate drawers on nylon rollers.
- Durable, 5 knuckle institutional hinges.
- Optional Lock (1 Door) or Lock-Bolt (2 Doors) available.

MODEL	WIDTH	DEPTH	HEIGHT
8248-84-346	48"	23"	76"
8248-84-927	48"	23"	76"
8248-84-5904	48"	23"	76"

B. MODEL 8154 SINGLE DOOR STORAGE CABINET

SPECIAL FEATURES:

- (1) door and (5) adjustable shelves.
- Durable, 5 knuckle institutional hinges.
- Optional Lock available.

MODEL	WIDTH	DEPTH	HEIGHT
8154-346	24"	23"	76"
8154-927	24"	23"	76"
8154-5904	24"	23"	76"

C. MODELS A9590, A9594 PRO-LOCKERS



- Dowel and glue oak laminate wood construction with 3mm high-impact edging.
- Foot locker with vented storage and hinged laminate seat (upholstered on A9594) with hasp for padlock.
- Double prong clothes hooks.
- Chrome clothes rod on A9590 only.
- Cabinets & lockers must be secured to the wall and can be detached and moved if necessary. Wall fasteners not included.
- Can be manufactured to be ADA compliant.
- Quantity discount available for large orders.

MODEL	WIDTH	DEPTH	HEIGHT
A9590	32"	22"	78"
A9594	18"	24"	78"

OPTIONS

MODELS A9590, A9594

- A9591** – Locking Security Door (for A9590)
- A9595** – Locking Security Door (for A9594)



C. MODELS A9590, A9594
Shown with optional locking security door



**CONTACT US ABOUT
CUSTOM LOCKER
CONFIGURATIONS**



Group B-401
Consists of: (L to R)
(1) B-24-2D and
(1) B-24

A variety of other base and wall cabinets are available. Call for information.

COMMON FEATURES



PRO-LINE™ PROFESSIONAL CABINETS:

- A versatile line of modular all-laminate, dowel and glue cabinetry.
- Neutral color all-laminate interiors.
- All cupboards (except sink) have (1) adjustable laminate shelf.
- 4" Satin finish wire pulls.
- Self-closing laminate drawer slides with nylon rollers and positive stops.
- Doors have concealed, self-closing 110° 3-Way adjustable Euro-Hinges.
- All doors and drawer fronts have 3mm high impact edging.
- All medical cabinets are "No Cancel/No Return."

COLORS: (SEE COLOR CHART THIS PAGE)

Cabinet - Folkstone Gray, Natural Oak or Wild Cherry laminate on all exposed surfaces including sides.

Countertop - Folkstone Gray square-edged top or choice of eight high pressure laminates with matching 3mm PVC edging.

BASE CABINETS - 36"H; CHOOSE 18"D OR 24"D. PRICES INCLUDE COUNTERTOP.

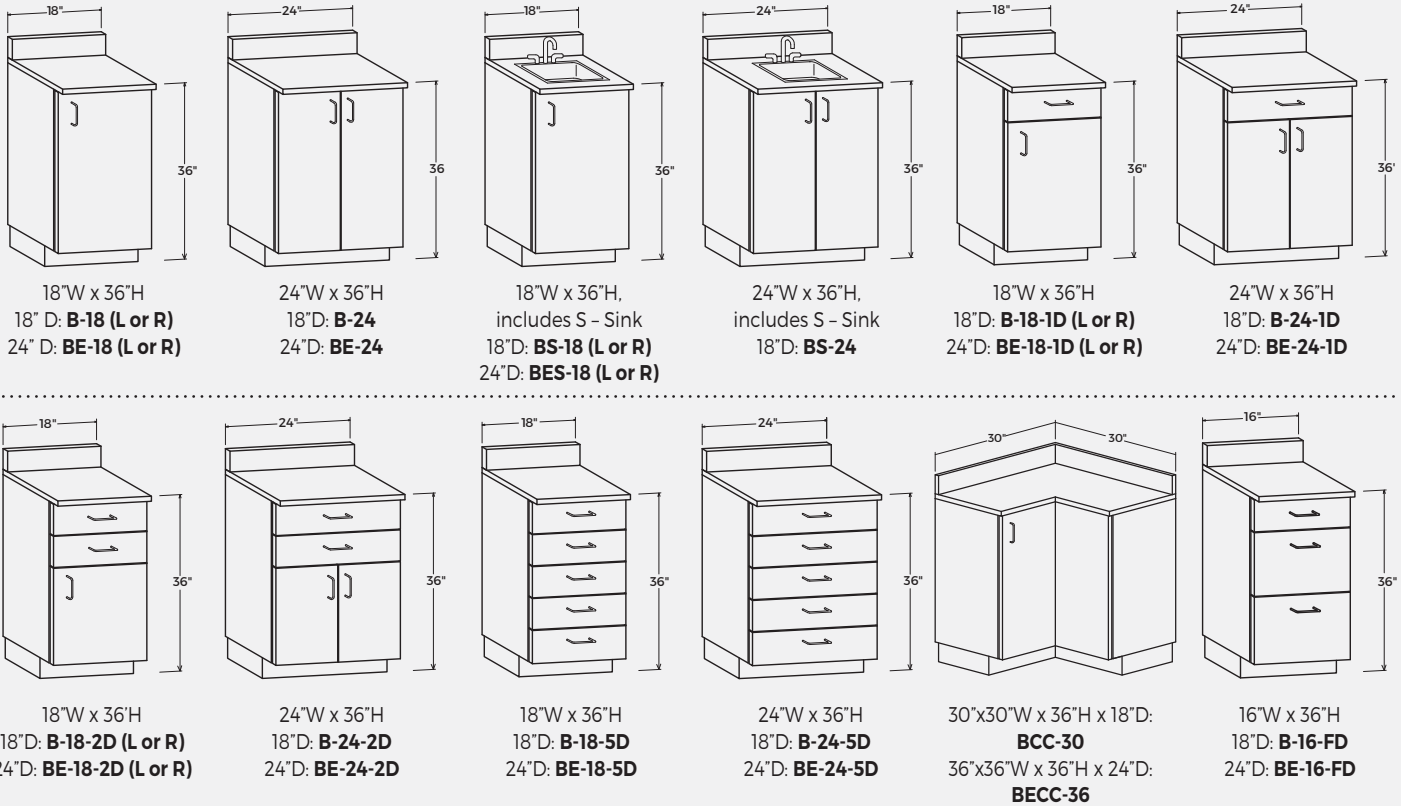

TYPICAL CABINET GROUPINGS (AVAILABLE AS SHOWN OR OPPOSITE HAND)

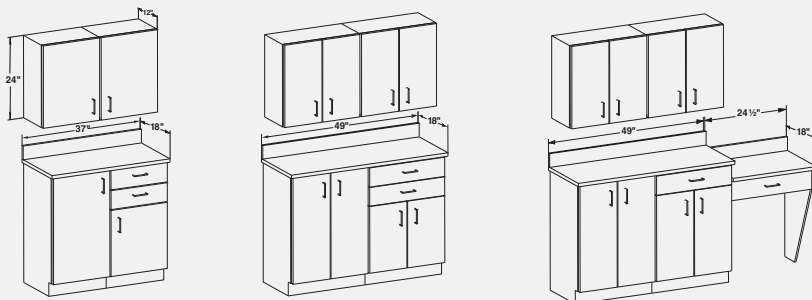

GROUP B-402

GROUP B-403

GROUP B-404

LAMINATE COUNTERTOP COLOR CHOICES



PRO-LINE™ CABINETRY

Price includes enough countertop to cover each base cabinet. Order GTP-TOP below for extended countertops. Must specify hinging on (l) door cabinets: R = Right Hinged / L = Left Hinged. Cabinet selection and countertop size can be varied to suit your needs. Groups are available as shown or opposite hand. All groups available with optional S sink. (Please specify on order.)

WALL CABINETS - 12"D; CHOOSE 24"H OR 30"H.

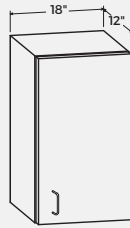

18"W x 12"D
24"H: **W-18-24 (L or R)**
30"H: **W-18-30 (L or R)**

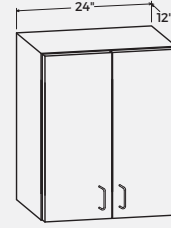

24"W x 12"D
24"H: **W-24-24**
30"H: **W-24-30**

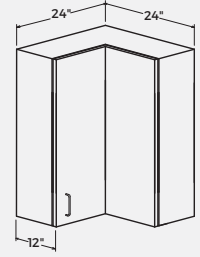

24" x 24"W x 12"D
24"H: **WCC-24-24**
30"H: **WCC-24-30**

ACCESSORIES

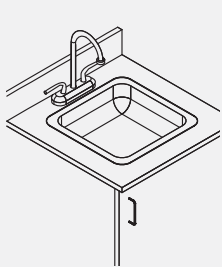

S
Sink/Faucet/Strainer

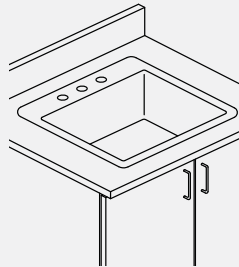

S-LRG
Large Sink
(no faucet)

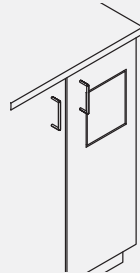

PL-TD
Towel Drop

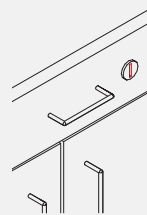

LOCK
Drawer/Door

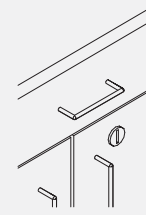

LOCK-BOLT
Double Door

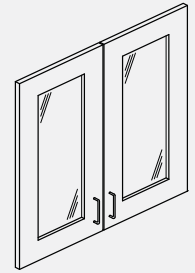

PGD-24, 24"H
PGD-30, 30"H
Plexiglass doors for wall cabinets

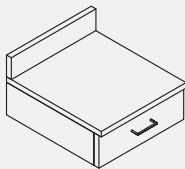

Desk drawer
18"W x 6"H
18"D: **D-18**
24"D: **DE-18**

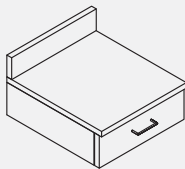

Desk drawer
24"W x 6"H
18"D: **D-24**
24"D: **DE-24**

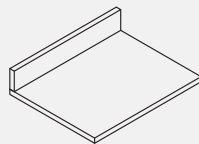

Countertop
Cut to size
18"D: **GTP-TOP**
24"D: **GTPE-TOP**



Desk end panel
D-EP
¾"W x 29"H
Specify depth



Cabinet end panel
B-EP
Specify depth



Wall filler
WF-24
WF-30
Cut to size



Base cabinet filler
B-F
Cut to size

STORAGE AND WARDROBES - 24"D x 78"H; CHOOSE 24"W, 30"W, OR 36"W.

A. Storage Cabinet

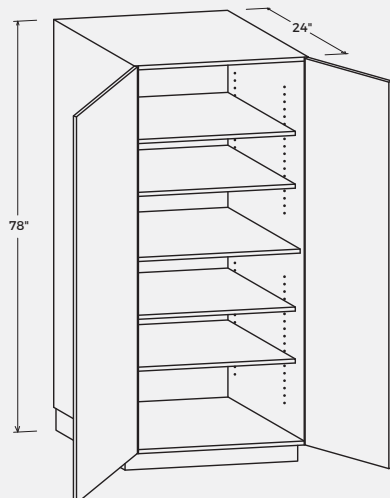

A. Storage Cabinet

- (1) Fixed shelf (36" from bottom)
- (4) Adjustable shelves
- 24"W: **SCS-24**
- 30"W: **SCS-30**
- 36"W: **SCS-36**

B. Wardrobe Cabinet

- (1) Fixed shelf (12" from top)
- (1) Adjustable wardrobe rod
- (2) Adjustable shelves
- 24"W: **SCW-24**
- 30"W: **SCW-30**
- 36"W: **SCW-36**

B. Wardrobe Cabinet

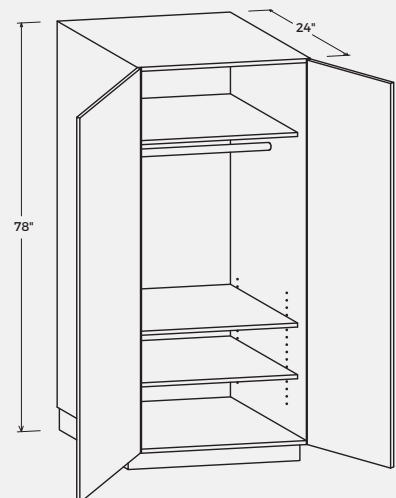

MEDICAL CABINETS

A. MODEL GLR-B4 FREE-STANDING CABINET UNIT

FEATURES:

- (5) 24" wide Drawers on nylon rollers.
- (1) 24" wide storage Door section with adjustable shelf.
- 36" high Countertop surface.
- (2) 24" wide x 10" deep upper solid door cupboards each with (1) adjustable shelf.

MODEL	LENGTH	DEPTH	HEIGHT
GLR-B4	49½"	18"	77"



A. MODEL GLR-B4



B. MODEL GLR-A1

B. MODEL GLR-A1 FREE-STANDING UNIT WITH SINK

FEATURES:

- (2) 24" wide Drawers with Doors below.
- (1) 24" wide Door section with shelf.
- 36" high Countertop surface.
- (4) Upper Framed Acrylic Doors.
- (2) Upper 10" deep cupboards with shelf.
- Stainless Steel Sink (10"x12"x5") and Faucet.

MODEL	LENGTH	DEPTH	HEIGHT
GLR-A1	49½"	18"	77"

CABINETRY INSTALLATIONS



MODEL #	PAGE	QS	NP/ND	MODEL #	PAGE	QS	NP/ND	MODEL #	PAGE	QS	NP/ND	MODEL #	PAGE	QS	NP/ND	MODEL #	PAGE	QS	NP/ND
30-43	38	3		5502	30	1		8250-100	37			A9023	42	10		A9531	4		
1310	40	3		5503	30	1		8251	37			A9024	10	5		A9532	4		
1412	28	5		5505	30	1		8252	37			A9041	10	5		A9533	4		
1418	28	10		5510-V to 5519-V	30	1		8252-100	37			A9063	14	10		A9534	4		
1419	28	10	NP					8253	37			A9064	13						A9535
1420	28	5		5531	32	1		8728	42	3		A9065	13			A9540	4		
1421	28	5		5539	31	1		9018-20	43	5		A9066	11			A9541	4		
1425	29	10		5541	31	1		9029-8	43	5		A9067	11			A9542	4		
1427	27	10		5545	31	1		9029-24	43	5		A9068	13			A9543	4		
1428	27		NP	5555	31	1		9038-20	43	5		A9069	15		NP	A9544	4		
1429	27	10		5555-100	31	1		9210	43	10		A9070	15		NP	A9545	4		
1440	26	5		5556	36	10		A900	9			A9071	15		NP	A9590	45		
1441	26	10		5556-100	36	10		A901	9			A9073	11			A9594	45		
2010	40	1		5557	34	10		A902	9			A9075	17		NP	A9718	14		
2018	40	3		5557-100	34	10		A903	9			A9078	17		NP	AT810	21		
2038	40	3		5558	33	10	NP	A904-A908	9			A9087	10	10		AT815	21		
2116	39	3		5558-100	33	10	NP	A910	9			A9088	14	10		AT820	21		NP
2151	39	5		5560	33	5		A911	9			A9093	10	5	NP	AT825	21		NP
2153	39	3		5560-100	33	5		A912	9			A9097	10	5	NP	ATT2472	20	10	
2153-S	39	3		5562	35	5		A914	5			A9250	5			ATT2478	20	10	
2156-707	39	1		5562-100	35	5		A918	5			A9400	3		NP	ATT2772	20	10	
2157	39	3		5563	35			A923	5			A9401	3		NP	ATT2778	20	10	
2157-S	39	3		5563-100	35			A924	5			A9500	6			ATT3072	20	10	
2410	40	1		5565	32	1		A926	5			A9501	6			ATT3078	20	10	
3003	38	1		5565-100	32	1		A927	5			A9502	6			ATT314	20		
4061	19			5566	34	10		A929	5			A9503	6			ATT385	20	10	
4062	19		NP	5566-100	34	10		A931	29		NP	A9504	6			ATT386	20	10	
4075	18	5		5569	36	5		A932	29		NP	A9505	6			B-18 to BS-24	46		NP
4079	12		NP	5569-100	36	5		A933	29		NP	A9506	6			B-401	46		
4082	18	5		5570	32	1		A941	5			A9507	6			B-402	46		
4143	12	5		5570-100	32	1		A943	5			A9508	6			B-403	46		
4420	25	10		5571	32	1		A944	5			A9509	6			B-404	46		
4420-LD	25	10		5576	31	10		A945	5			A9510	6			CLR-A1	48		
4421	25	10		5576-100	31	10		A946	5			A9511	6			CLR-B4	48		
4421-LD	25	10		5580	30	1		A947	5			A9512	6			LOCK	47		
4423	25	10		5581	30	1		A961	17		NP	A9513	6			LOCK-BOLT	47		
4423-LD	25	10		5588	30	1		A962	17		NP	A9514	6			S	47		
4424	25	10		5592	34	10		A963	17		NP	A9515	6			S-LRG	47		
4424-LD	25	10		5592-100	34	10		A964	17		NP	A9516	6			SCS-24 to SCW-36	47		NP
4710	22	3		6053	24	5		A965	17		NP	A9517	6			W-18 to W-24	47		
4718	22			6071	24		NP	A966	17		NP	A9520	4						
4719	22	10		6074	24	10	NP	A9002	10	5		A9520-346-24	4	5					
4746	23			6695	36	3		A9014	41	10		A9521	3,4						
4747	23			7650-751	18	1		A9015	41	10		A9522	4						
4750	23	10		7650-752	18	1		A9016	41			A9523	4						
4756	23			8154	45			A9017	41			A9524	4						
4757	23			8248-84	45			A9021	17		NP	A9525	4						
4839	12	10		8250	37			A9022	42	10		A9530	4						

LEGEND

1 QUICK SHIP - 1 DAY

3 QUICK SHIP - 3 DAYS

5 QUICK SHIP - 5 DAYS

10 QUICK SHIP - 10 DAYS

NP NEW PRODUCT

ND NEW DESIGN



More Information.
Latest Updates.
Special Promotions.



HAUSMANN INDUSTRIES, INC.
130 Union Street
Northvale NJ 07647
USA



CAT. #1016-PRO
©2016 HAUSMANN INDUSTRIES, INC.

RECYCLED PAPER
PRINTED IN THE USA

CALL

201-767-0255
888-HAUSMANN

FAX

201-767-1369
877-7FREEFAX

EMAIL

sales@ProteamTables.com
info@Hausmann.com

WEB

ProteamTables.com
Hausmann.com



Scan for
Savings

